

# ***FM Stereo/FM-AM Receiver***

---

Operating Instructions

*STR-D1011*

# Warning

## WARNING

To prevent fire or shock hazard, do not expose the unit to rain or moisture.

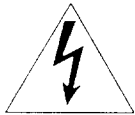
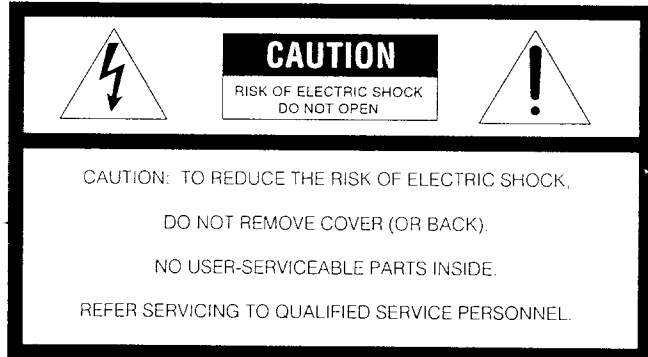

This symbol is intended to alert the user to the presence of uninsulated "dangerous voltage" within the product's enclosure that may be of sufficient magnitude to constitute a risk of electric shock to persons.



This symbol is intended to alert the user to the presence of important operating and maintenance (servicing) instructions in the literature accompanying the appliance.

### Owner's Record

The model number is located on the rear exterior and serial number is on the rear. Record the serial number in the space provided below. Refer to these numbers whenever you call upon your Sony dealer regarding this product.

Model No. \_\_\_\_\_ Serial No. \_\_\_\_\_

### Note to CATV system installer

This reminder is provided to call the CATV system installer's attention to Article 820-40 of the NEC that provides guidelines for proper grounding and, in particular, specifies that the cable ground shall be connected to the grounding system of the building, as close to the point of cable entry as practical.

### INFORMATION

This equipment has been tested and found to comply with the limits for a Class B digital device, pursuant to Part 15 of the FCC Rules. These limits are designed to provide reasonable protection against harmful interference in a residential installation. This equipment generates, uses, and can radiate radio frequency energy and, if not installed and used in accordance with the instructions, may cause harmful interference to radio communications. However, there is no guarantee that interference will not occur in a particular installation. If this equipment does cause harmful interference to radio or television reception, which can be determined by turning the equipment off and on, the user is encouraged to try to correct the interference by one or more of the following measures:

- Reorient or relocate the receiving antenna.
- Increase the separation between the equipment and receiver.
- Connect the equipment into an outlet on a circuit different from that to which the receiver is connected.
- Consult the dealer or an experienced radio/TV technician for help.

### CAUTION

You are cautioned that any changes or modifications not expressly approved in this manual could void your authority to operate this equipment.

### For the customers in Canada

#### CAUTION :

TO PREVENT ELECTRIC SHOCK, DO NOT USE THIS POLARIZED AC PLUG WITH AN EXTENSION CORD, RECEPTACLE OR OTHER OUTLET UNLESS THE BLADES CAN BE FULLY INSERTED TO PREVENT BLADE EXPOSURE.

This apparatus complies with the Class B limits for radio noise emissions set out in Radio Interference Regulations.

### CAUTION

Use of this appliance with some systems may present a shock or fire hazard. Do not use with any units which have the following marking located near output, WARNING: HAZARDOUS ENERGY !.

# Table of Contents

<b>Introduction</b>		
Overview .....	4	
Precautions .....	5	
<b>Chapter 1 Getting Started</b>		
Unpacking .....	5	
Checking the supplied accessories .....	5	
Inserting the batteries into the remote commander .....	5	
Selecting the AM tuning interval .....	5	
Hooking up the system .....	6	
Connecting an FM antenna .....	6	
Connecting an AM antenna .....	6	
Connecting audio equipment .....	7	
Connecting video equipment .....	7	
Connecting speaker systems .....	8	
Connecting to the power outlet .....	9	
Selecting the mode of the FUNCTION/ SOUND FIELD/PRESET TUNING buttons .....	9	
Identifying the parts and controls .....	10	
Front panel .....	10	
Remote commander (U.S.A. model only) .....	12	
<b>Chapter 2 Basic Operations</b>		
Operating with the remote commander .....	13	
Changing the settings of the FUNCTION buttons .....	13	
Adjusting basic audio controls .....	14	
Adjusting volume .....	14	
Adjusting left and right sound balance .....	14	
Reinforcing the bass .....	14	
Selecting the speaker system .....	14	
Selecting a program source .....	15	
To turn off the power at the desired time (The sleep timer function) .....	15	
Labeling the program source .....	16	
Receiving broadcasts .....	17	
Tuning in a station directly (Direct tuning) .....	17	
Automatic tuning .....	18	
Presetting stations (Station preset) .....	19	
Tuning in a preset station (Preset tuning) .....	20	
Labeling the preset stations (Station index) .....	21	
Selecting a station among the preset stations in the index (Index tuning) .....	22	
Receiving FM simulcast TV programs .....	22	
Selecting a factory-preset sound effects .....	23	
Recording an audio source .....	24	
Recording onto an audio tape deck or DAT deck .....	24	
Tape dubbing .....	24	
Editing a video source .....	25	
Video tape dubbing .....	25	
Adding new sound on a video tape during video editing .....	26	
<b>Chapter 3 Advanced Operations</b>		
What is the digital signal processor? .....	27	
Sound field setting .....	28	
Table of adjustable parameters .....	28	
Getting ready for Dolby surround sound .....	29	
Placement of speakers and selecting the PRO LOGIC MODE .....	29	
Adjusting the speaker volume .....	30	
Adjusting the delay time of the rear speakers .....	31	
Adjusting the SOUND FIELD program .....	32	
Understanding the digital surround processor .....	32	
Characteristics of the SOUND FIELD program .....	32	
Adjusting the surround effect .....	33	
Understanding the digital parametric equalizer .....	36	
How to adjust the digital parametric equalizer .....	36	
Enjoying with your private setting .....	37	
Calling up the sound field setting .....	37	
Linking the sound field memory to preset stations or program sources .....	37	
<b>Chapter 4 Other Information</b>		
Troubleshooting guide .....	38	
Specifications .....	40	
Quick reference .....	42	

# Overview

The STR-D1011 is an FM Stereo/FM-AM receiver and audio/video control center. You can enjoy various audio/video program sources with this unit.

## TV/video programs

- You can enjoy TV or CATV programs with FM simulcast.
- Sounds from various audio program sources can be added on video tapes during editing.

## Tuner

- Precise tuning is ensured by a quartz locked digital synthesizer.
- Station index system allows you to tune into a station quickly.

## Digital surround processor

- The STR-D1011 electronically reproduces the reflected sound (early reflection) and reverberation sound (reverberation) by using its digital signal processor, and allows you to obtain the acoustics of various situations.
- **DOLBY\* PRO LOGIC:** The STR-D1011 incorporates the Dolby Pro Logic Surround Decoder which has the same functions for playback as movie theaters and gives a theater-like experience in your listening room, naturally reproducing the audio sound field.

\* Manufactured under license from Dolby Laboratories Licensing Corporation. Additionally licensed under one or more of the following patents: U.S. number 3,959,590; Canadian numbers 1,004,603 and 1,037,877. "DOLBY", "Pro Logic", and the double-D symbol are trademarks of Dolby Laboratories Licensing Corporation.

## Digital parametric equalizer

You can enjoy audio program sources with appropriate equalization curve by controlling the level of the desired 3 frequency bands.

## Sound field

- 10 recommended sound field programs (combination of surround and parametric equalizer settings) are preset in the factory for easy use. You can also store up to 10 settings you created in the memory.
- Combined use of the sound field programs and the preset stations allow you to enjoy broadcast listening immediately with the memorized sound field settings.

## The FUNCTION/SOUND FIELD/PRESET TUNING buttons

There are two kinds of modes for the FUNCTION/SOUND FIELD/PRESET TUNING buttons. One is the "Auto mode" and the other is the "Manual mode". With these modes, you can conveniently operate this receiver.

This manual describes the operations in the auto mode.

## Remote commander supplied

This unit is supplied with the remote commander.

For the instruction of the remote commander for Canada model, see the operating instructions of the separate volume.

# Precautions

## On safety

- Operate the unit only on 120 V AC, 60 Hz.
- Should any solid object or liquid fall into the cabinet, unplug the unit and have it checked by qualified personnel before operating it any further.
- Unplug the unit from the wall outlet if it is not to be used for an extended period of time. To disconnect the cord, pull it out by grasping the plug. Never pull the cord itself.
- One blade of the plug is wider than the other for the purpose of safety and will fit into the power outlet only one way. If you are unable to insert the plug fully into the outlet, contact your dealer.

**To prevent internal heat buildup in the unit,** place the unit in a location with adequate air circulation.

## Do not install the unit:

- near heat sources such as radiators or air ducts.
- in a place subject to direct sunlight, excessive dust, mechanical vibration or shock.

## Do not place anything on top of the cabinet.

The top ventilation holes must be unobstructed for the proper operation of the unit and to prolong the life of its components.

## Do not throw away the carton and packing material!

It will be an ideal container when transporting the system for repair work, etc.

## On operation

Before making program source connections, be sure to turn the power switch off and unplug the unit.

## On cleaning the cabinet

Clean the cabinet, panel and controls with a soft cloth lightly moistened with mild detergent solution. Do not use any type of abrasive pad, scouring powder, or solvent such as alcohol or benzene.

## For the customers in the U.S.A.

For detailed safety precautions, see the "IMPORTANT SAFEGUARDS" leaflet.

If you have any question or problem concerning your unit, please consult your nearest Sony dealer.

# Unpacking

## Checking the Supplied Accessories

After unpacking, check that the following accessories are present.

- FM wire antenna ..... (1)
- AM loop antenna ..... (1)
- Remote commander ..... (1)
- Sony batteries SUM-3 (NS) ..... (2)

## Inserting the Batteries into the Remote Commander

Before operating remote commander, install the batteries as shown.

**1** Open the cover.

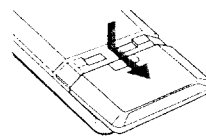

**2** Two size AA (R6) batteries with correct polarity.

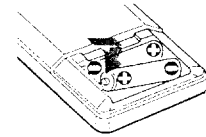

## To avoid damage caused by battery leakage and corrosion

When the commander will not be used for a long time, remove the batteries.

## Battery life

Normal operation can be expected about a half year using Sony SUM-3 (NS), and a year using Sony AM-3 (NW) alkaline batteries.

When the batteries are run down, the remote commander will not operate the unit. In this case, replace batteries with new ones.

## Selecting the AM Tuning Interval

The AM tuning interval is preset to 10 kHz. To use the receiver where the frequency allocation system is based on a 9 kHz interval, make the following adjustments.

- 1** Turn on the power and tune in any AM station.
- 2** Turn off the power.
- 3** Press the POWER button while pressing the INDEX SELECT/TUNING + button.

To reset the AM tuning interval, repeat the above steps.

## Caution

When the interval is changed, all preset stations which you have memorized will be erased. After changing the interval, be sure to preset the stations again.

# Hooking Up the System

At first, this section describes about the antenna connection and then the connection with the other equipment. After that, it shows about the speaker connection and about the AC outlet.

- Do not connect the power cord to an AC outlet nor press the POWER switch before accomplishing all other connections.
- The cable connectors should be fully inserted into the jacks. Loose connection may cause hum and noise.
- Jacks and plugs of the connecting cord are color-coded as follows:  
Red jacks and plugs: For the right channel of audio signals  
White jacks and plugs: For the left channel of audio signals  
Yellow jacks and plugs: For video signals

## Connecting an FM Antenna

Though the wire antenna is supplied with this unit, the higher quality sound will be obtained with the 75-ohm coaxial cable.

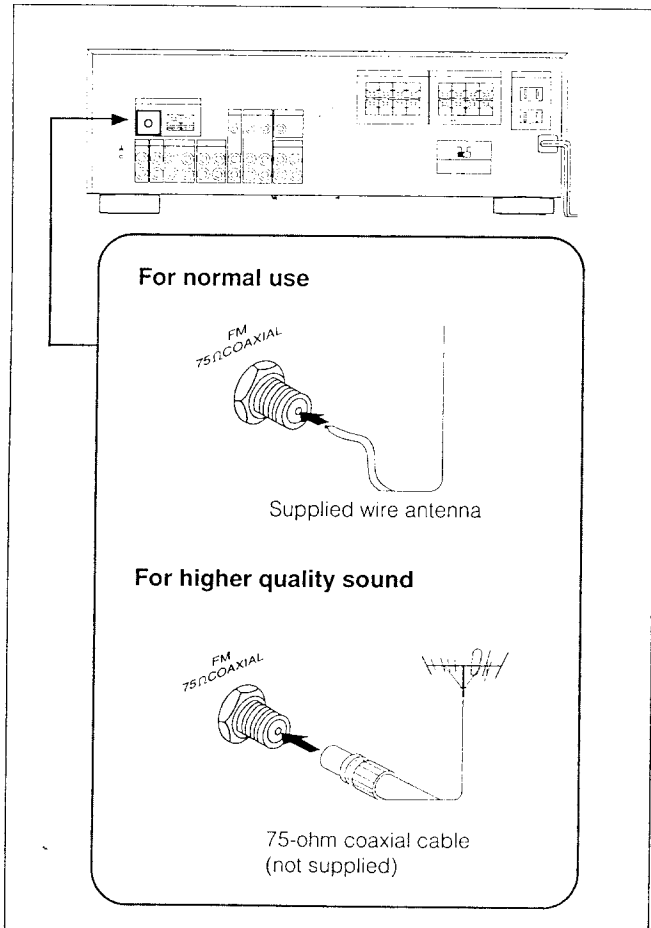

## Connecting an AM Antenna

The AM broadcast is enough received with the supplied AM loop antenna. However, the connection of insulated wire is also available for areas with difficult AM reception.

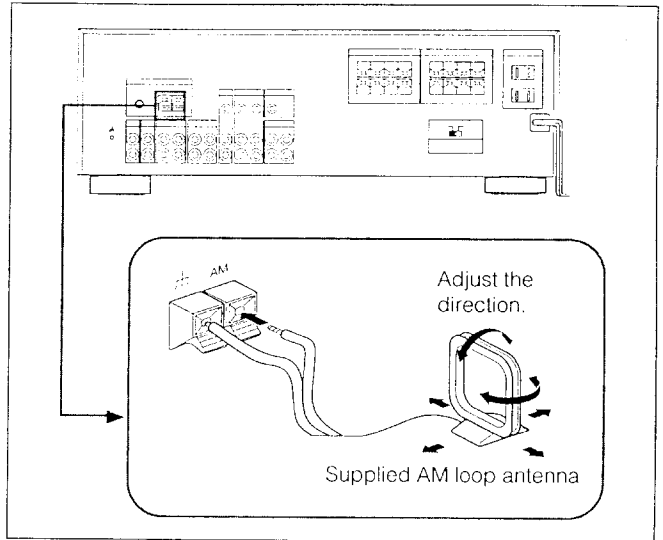

### For areas with difficult AM reception

In areas with troubled reception, connect a 6 to 15-meter (20 to 50-feet) insulated wire to the AM antenna terminal. Extend this out of doors if possible, keeping the greater portion horizontal. (There is no need to disconnect the supplied antenna.)

### To prevent hum

Connect the ground wire to ANTENNA ground terminal (⚡). When an outdoor antenna is installed, be sure to connect the ground wire for lightning protection.

## Connecting Audio Equipment

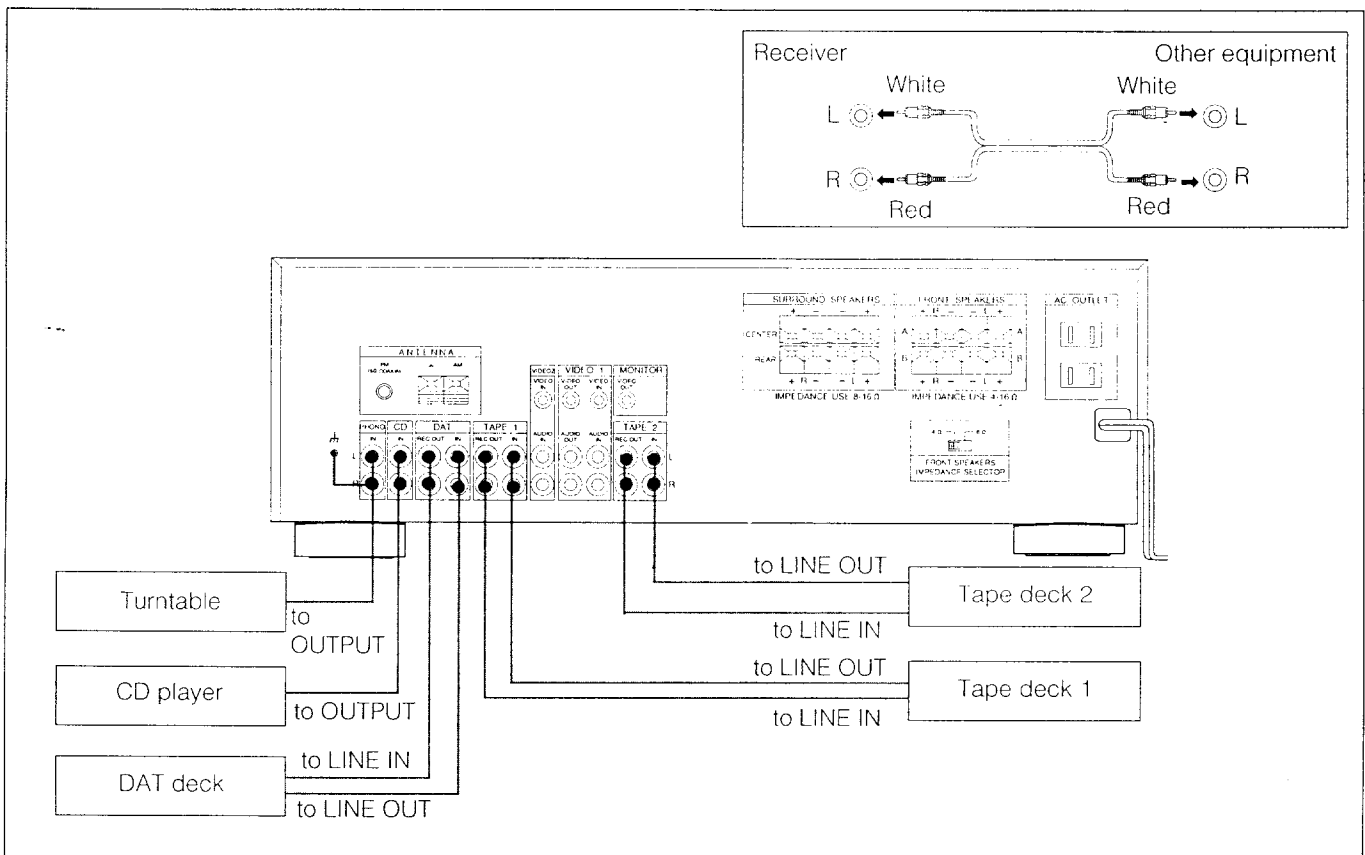

## Connecting Video Equipment

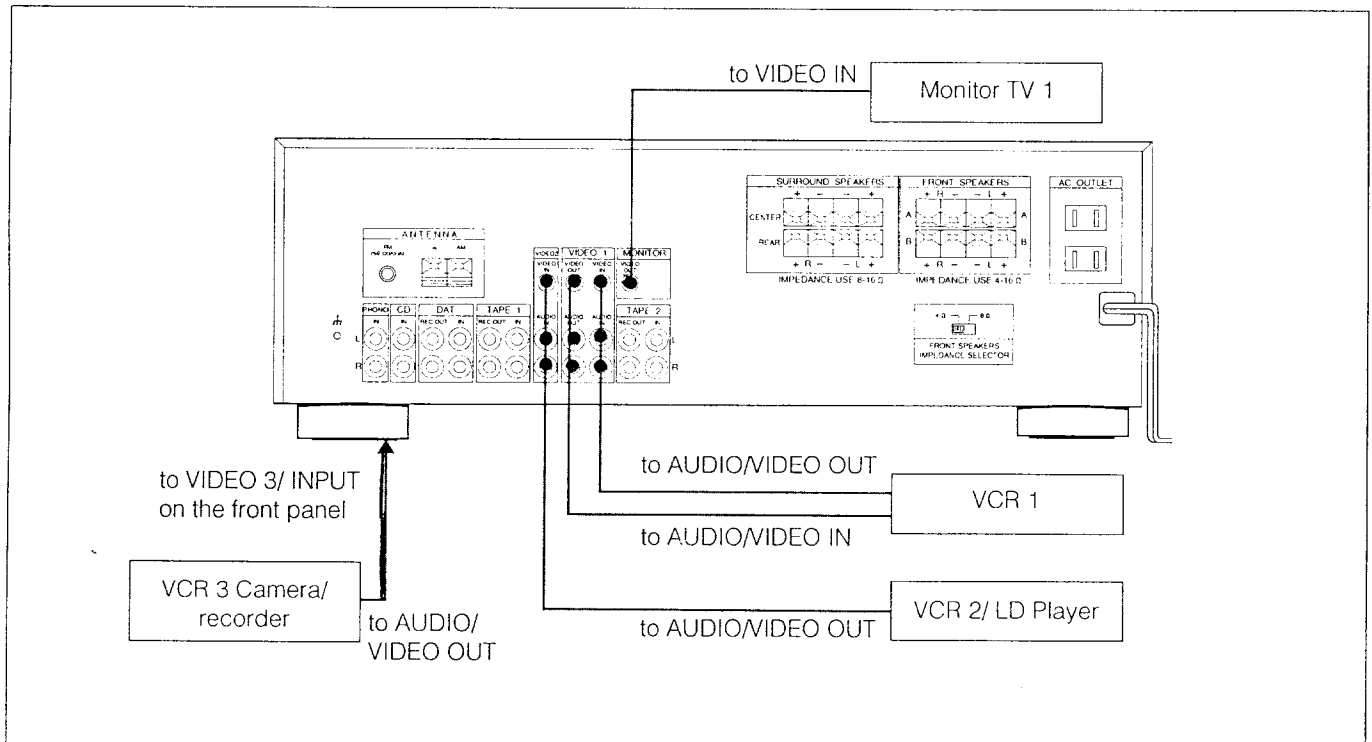

# Hooking Up the System

## Connecting Speaker Systems

Front, center and rear speakers can be connected to this unit.

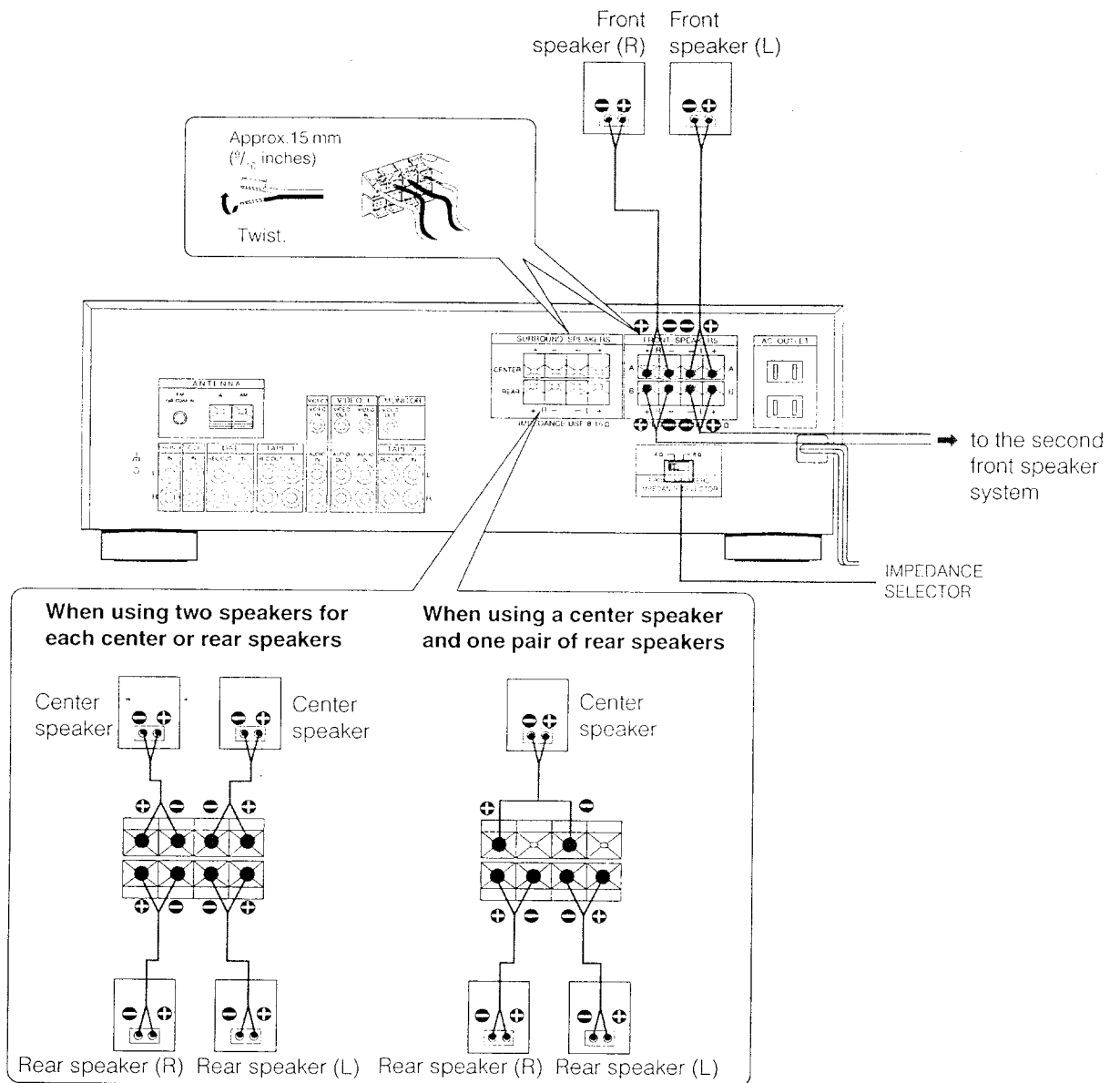

### On the IMPEDANCE SELECTOR

The STR-D1011 has the IMPEDANCE SELECTOR for front speakers.

When using the front speakers having nominal impedance from 4 ohms or higher, set to the 4  $\Omega$  position.

When using the front speakers having nominal impedance from 8 ohms or higher, set to the 8  $\Omega$  position.

### Note

Use the front speakers having nominal impedance of more than 8 ohms in the SURROUND mode.

### Note

When connecting the speaker cord to the speaker terminal, make sure that the polarity (+ and -) of the speaker cord is correct. If the polarity is reversed at either speaker, the sound will be distorted and will lack bass.



## Connecting to the Power Outlet

By connecting the power cord of the other audio equipment to SWITCHED AC OUTLET, this unit can supply the power source to the other audio equipment.

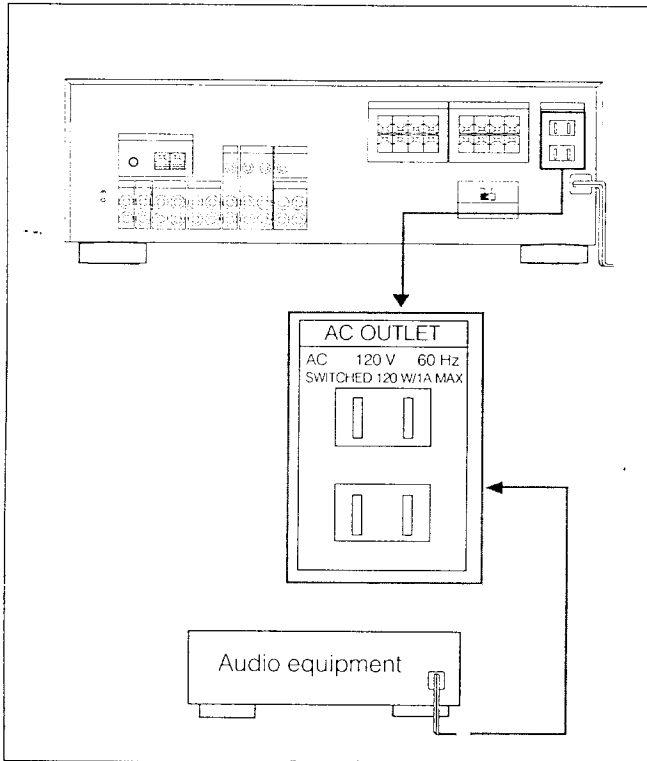

### Caution

Be careful that the total power consumption of each equipment connected to the outlets on the receiver does not exceed 120 watts.

Do not connect electrical home appliances such as an electric iron, fan, TV, or other high-wattage equipment to these outlets.

## Selecting the Mode of the FUNCTION/SOUND FIELD/PRESET TUNING Buttons

There are two kinds of modes for the FUNCTION/SOUND FIELD/PRESET TUNING buttons. One is the "Auto mode" and the other is the "Manual mode".

### • Auto mode

The FUNCTION/SOUND FIELD/PRESET TUNING buttons are factory preset to the auto mode: After one of the FUNCTION buttons, SOUND FIELD LINK, SOUND FIELD ON/OFF or SOUND FIELD USER/PRESET is pressed, the FUNCTION/SOUND FIELD/PRESET TUNING buttons change to the SOUND FIELD mode automatically. When TUNER is pressed, these buttons function as numeric buttons.

### • Manual mode

When you press the POWER switch while pressing MODE SELECT, the FUNCTION/SOUND FIELD/PRESET TUNING buttons are set to the manual mode. With MODE SELECT, you can select the desired mode. To return to the auto mode, perform the same procedure again.

# Identifying the Parts and Controls

## Front Panel

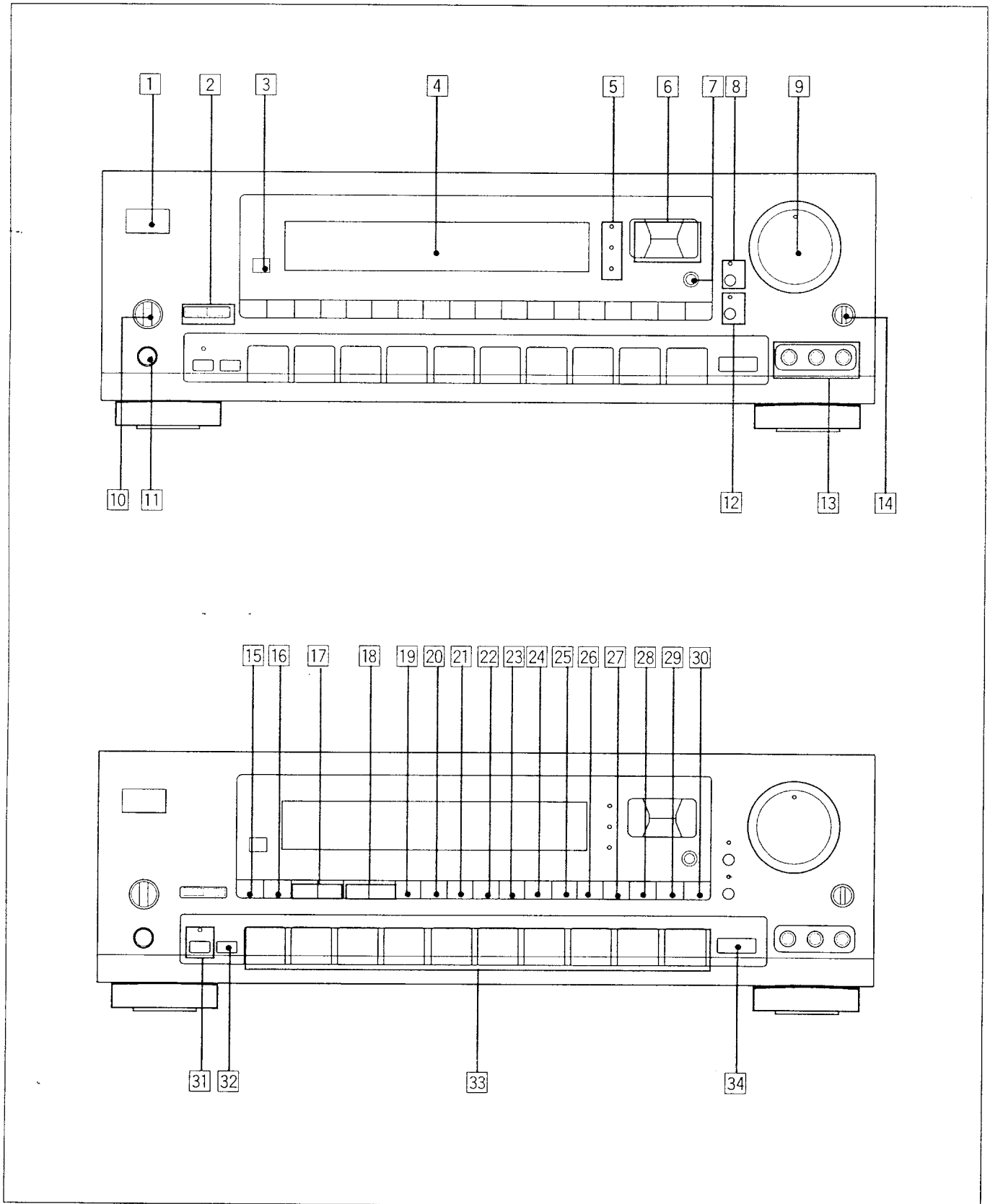

- 1 **POWER switch**
- 2 **EDIT VIDEO/AUDIO buttons** (See pages 25, 26.)
- 3 **Remote sensor**
- 4 **Display**
- 5 **CURSOR MODE indicators**  
(See pages 16, 21, 30, 31, 33, 36.)
- 6 **Cursor mode operation buttons**  
(See pages 16, 21, 30, 31, 33, 36.)
- 7 **CURSOR MODE button**  
(See pages 16, 21, 30, 31, 33, 36.)
- 8 **DBFB button and indicator** (See page 14.)
- 9 **MASTER VOLUME control** (See page 14.)
- 10 **SPEAKERS selector** (See page 14.)
- 11 **HEADPHONES jack**
- 12 **MUTING button and indicator** (See page 14.)
- 13 **VIDEO 3/INPUT jacks**
- 14 **BALANCE control** (See page 14.)
- 15 **DISPLAY GRAPHIC button** (See page 36.)
- 16 **DISPLAY INDEX button** (See pages 18, 22.)
- 17 **INDEX SELECT/TUNING -/+ buttons**  
(See pages 18, 22.)
- 18 **PRESET TUNING -/+ buttons** (See page 22.)
- 19 **TUNING LEVEL button** (See page 18.)
- 20 **MEMORY button** (See pages 16, 19, 21.)
- 21 **DIRECT TUNING button** (See page 17.)
- 22 **FM MODE button** (See page 17.)
- 23 **FM/AM button** (See pages 17, 18.)
- 24 **SOUND FIELD LINK button** (See page 37.)
- 25 **SOUND FIELD ON/OFF button** (See pages 30, 31.)
- 26 **SOUND FIELD USER/PRESET button**  
(See pages 33, 36, 37.)
- 27 **DOLBY PRO LOGIC MODE button**  
(See pages 29, 30.)
- 28 **EQUALIZER FLAT button** (See page 36.)
- 29 **EQUALIZER SLOPE button** (See page 36.)
- 30 **EQUALIZER BAND button** (See page 36.)
- 31 **TAPE 2 MONITOR button and indicator**  
(See page 24.)
- 32 **SHIFT button** (See pages 19, 20, 21.)
- 33 **FUNCTION/SOUND FIELD/PRESET TUNING buttons**  
(See page 9.)
- 34 **MODE SELECT button** (See page 9.)

# Identifying the Parts and Controls

## Remote Commander (U.S.A. model only)

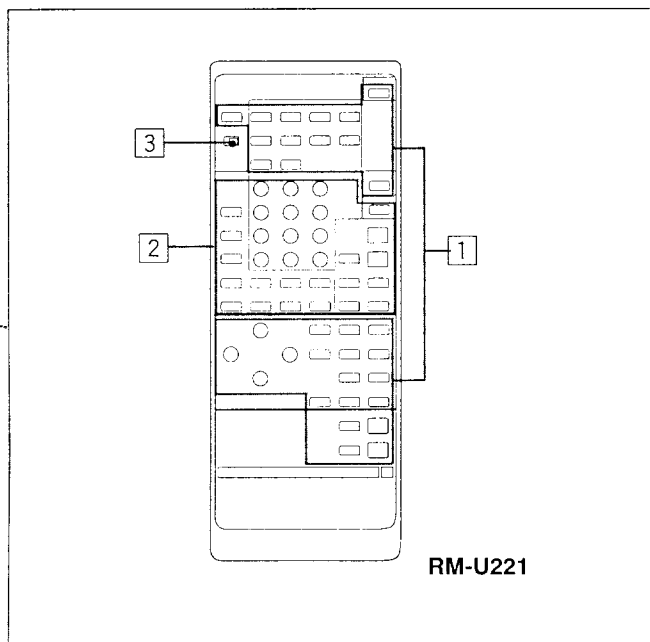

### 1 Receiver control section

FUNCTION:

DAT, CD, TUNER, PHONO, VIDEO 1, VIDEO 2, VIDEO 3, TAPE, DIGITAL 1, 2: The each function is selected and the each unit enters its operating mode automatically. (DIGITAL 1 and 2 do not function.)

SYSTEM OFF: Turns off the power of the whole system.

POWER: Turns on the power of the receiver

SOUND FIELD buttons

U/P (user/preset): Selects the USER or PRESET mode.

MODE: Selects the sound field mode.

ON/OFF: Turns on/off the sound field system.

BAND: Selects the frequency band of the equalizer.

EQ: Turns on/off the setting of TONE controls.

T. (test) TONE: Generates a pink noise signal that is sent in succession to each speaker.

CURSOR MODE: Select CURSOR MODE.

CURSOR operating buttons

REAR LEVEL +/- buttons: Control the volume of rear speakers (surround level).

CENTER LEVEL +/- buttons: Control the volume of center speaker (surround level).

DBFB button: Turns on/off the DBFB (Dynamic Bass Feedback).

MUTING button: Mutes the sound.

MASTER VOL +/- buttons: Control the receiver volume.

~ SLEEP: Set to the SLEEP timer mode. In this mode, the unit is automatically turned off after the designated time.

### 2 Other equipment control section

Numeric buttons (1 to 0): Designate the number.

ENTER: Press after designating the TV/VCR channel.

SHIFT: Select the memory page (A, B or C).

TV/VIDEO selector: Selects the program to see : TV or VIDEO.

ANT TV/VTR button: Selects the output signal from the antenna terminal on the VCR, either a TV signal or VCR programs.

CH/PRESET +/- buttons: Select a preset channel.

INDEX: Set to the index tuning mode.

◀◀/▶▶: Fast winding/manual search

●: Recording

◀▶: Play

■: Stop

||: Pause

I◀◀/▶▶: Locates a desired selection.

REV/FWD: Press ● and REV or FWD at the same time.

D (disc) SKIP: Disc skip (for a CD player equipped with a multi-disc changer)

SELECT: Changes the settings of the FUNCTION buttons.

### Notes

- The button which has no name does not function.
- When designating the selection number which is more than 10 in the CD, DAT or LD mode, press ▶▶ after pressing the appropriate numeric buttons.

### 3 SYSTEM/TV mode switch

**In TV mode (When setting the SYSTEM/TV selector to TV)**

Only MUTING, MASTER VOL +/- and the operative buttons in TV section on the list described on the next page can be used.

# Operating with the Remote Commander

Before operating the equipments with the remote commander, be sure to set the receiver to the desired mode by pressing one of the FUNCTION buttons.

The FUNCTION buttons are factory set in the following list.

FUNCTION to be pressed	Operating equipment
DAT	DAT deck
CD	CD player
TUNER	Tuner
PHONO	(The receiver enters the PHONO mode.)
VIDEO 1	Betamax VCR (VCR 1)
VIDEO 2	LD player
VIDEO 3	8 mm VCR (VCR 2)
TAPE	Tape deck A

- When VIDEO 1, 2 or 3 is pressed, the power of the selected video equipment and TV is turned on.

## Operating the equipment

- 1 Press the desired FUNCTION.
- 2 Press ◀ (only for tape deck) or ▶ to start playback.

## Changing the Settings of the FUNCTION Buttons

With the SELECT button, you can replace the functions stored in the FUNCTION buttons.

### To change the settings of the FUNCTION buttons

- 1 Press one of the FUNCTION buttons to be stored.
- 2 Press SELECT.
- 3 Press 1 to 9 button to select the desired function within 30 seconds.  
To reset to the initial state, press the blank button left next to the 0 button.
- 4 Press ENTER.

### To operate other unit temporarily without changing the settings of FUNCTION

- 1 Press SELECT.
- 2 Press the 1 to 9 button to select the function.
- 3 Press the desired button.  
After operating the unit, the receiver enters the previous mode.  
Operative buttons: POWER, ◀▶, ◀▶▶, ◀▶▶▶, ■, ◀▶, II, ●REC, D.SKIP, TV/VIDEO, ANT TV/VTR, CH/PRESET+/-, SHIFT, INDEX.

#### Example:

To record the program source on DECK A in the CD mode

- 1 Press SELECT.
- 2 Press 3 (DECK A).
- 3 While pressing ●, press REV or FWD.  
After operating DECK A, the receiver enters the CD mode automatically.

## List of operative buttons in SYSTEM mode (When setting the SYSTEM/TV selector to SYSTEM)

Operating equipment	TUNER	CD	DAT	DECK A, B	TV	LDP	VTR 1, 2, 3
1	•	•	•	—	•	•	•
2	•	•	•	—	•	•	•
3	•	•	•	—	•	•	•
4	•	•	•	—	•	•	•
5	•	•	•	—	•	•	•
6	•	•	•	—	•	•	•
7	•	•	•	—	•	•	•
8	•	•	•	—	•	•	•
9	•	•	•	—	•	•	•
0	•	•	•	—	•	•	•
ENTER	—	—	—	—	•	•	•
SHIFT	•	—	—	—	—	—	—
TV/VIDEO	—	—	—	—	•	•*	•*
ANT TV/VTR	—	—	—	—	—	—	•
CH PRESET +/-	•	—	—	—	•	—	•
INDEX	•	—	—	—	—	—	—
D.SKIP	—	•	—	—	—	—	—
▶▶	—	•	•	•	—	•	•
◀◀	—	•	•	•	—	•	•
▶▶I	—	•	•	—	—	•	—
I◀◀	—	•	•	—	—	•	—
II	—	•	•	•	—	•	•
◀	—	—	—	•	—	—	—
▶	—	•	•	•	—	•	•
■	—	•	•	•	—	•	•
REV + ●	—	—	—	•	—	—	—
FWD + ●	—	—	•	•	—	—	•

- : The button is operative.
- : The button is not operative.
- \*: The button can operate TV.

#### Note

To operate the unit correctly, the function mode of the receiver should be same with that of the remote commander. So, be sure to press the desired FUNCTION button at first and then the operative button.

## Adjusting Basic Audio Controls

You can enjoy superb sounds using the audio adjustment functions as shown below.

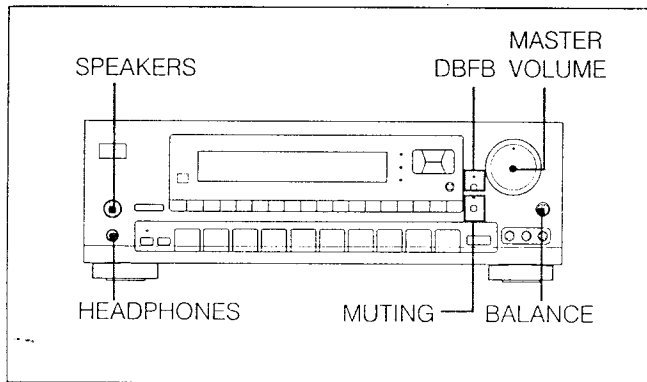

### Adjusting Volume

**To adjust volume**  
Turn MASTER VOLUME.

**To reduce the sound to a low level temporarily (- 20 dB attenuation)**  
Press MUTING. The indicator lights up.  
Press again to restore the same listening level as before.

### Adjusting Left and Right Sound Balance

Adjust BALANCE to correct stereo imaging, when the speaker position is not symmetrical.

### Reinforcing the Bass

Press DBFB (Dynamic Bass Feedback) so that the DBFB indicator lights up. Press again to turn off the effect so that the indicator goes off.

### Selecting the Speaker System

To drive speaker system A: Set SPEAKERS to A.  
To drive speaker system B: Set SPEAKERS to B.  
To drive both speaker systems A and B (series connection):  
Set SPEAKERS to A + B.  
For headphone listening: Connect headphones to HEADPHONES and set SPEAKERS to OFF.

#### IMPORTANT

Speaker systems A and B are series connected. When only one speaker system is connected, no sound can be heard at the A + B position.

# Selecting a Program Source

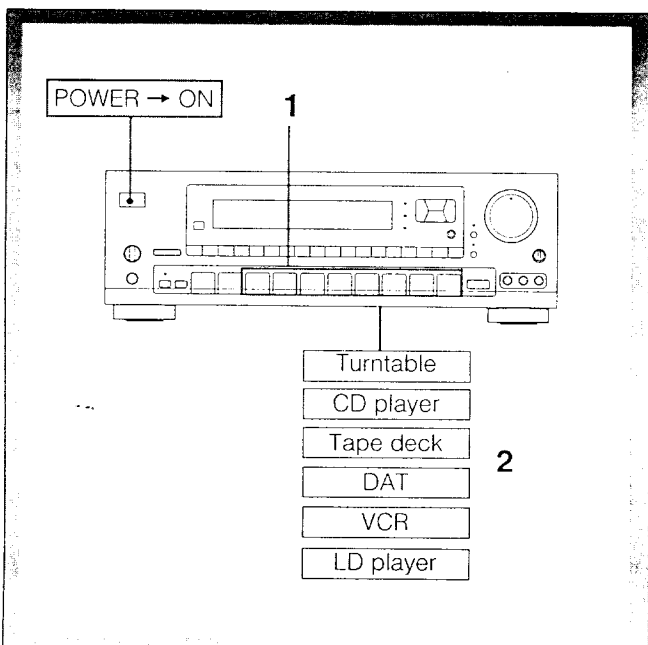

## 1 Select the program source.

What you select	Pressed
Phono record	PHONO
Radio Broadcast	TUNER
Compact disc	CD
DAT program	DAT
Taped program	TAPE 1, TAPE 2 MONITOR
Video program	VIDEO 1, VIDEO 2/LD, VIDEO 3

When one of the FUNCTION buttons is pressed, the indicator of the function you have selected appears on the display. Select the function with the remote commander, the power switches of both this receiver and the selected equipment are turned on.

## 2 Start playback of the selected program.

## To Turn Off the Power at the Desired Time (The Sleep Timer Function)

This receiver has the sleep timer function. With this function, you can turn off the power automatically at the desired time by designating the turn-off time. Press SLEEP on the remote commander when the power is on. Each time SLEEP is pressed, the designating time is displayed in the following order:

2 hours → 1 hour and 30 minutes → 1 hour → 30 minutes → SLEEP OFF.

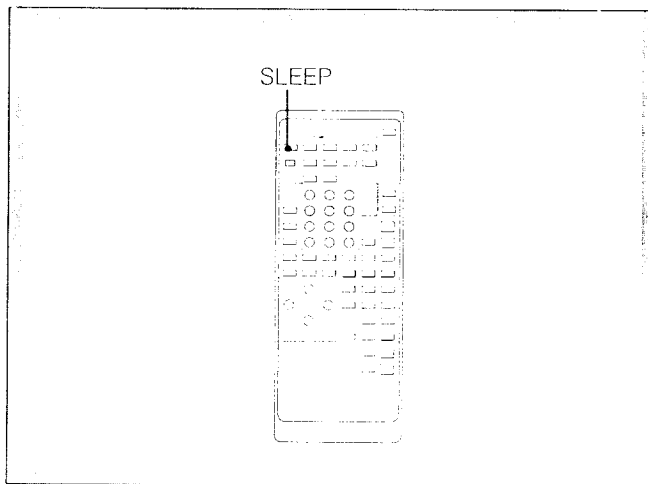

### To change the turn-off time

- 1 Press SLEEP and the remaining time is displayed.
- 2 Press  $\Delta$  or  $\nabla$  to change the sleep time. The sleep time is changed by 1 minute. It can be changed up to 6 hours and 00 minute (and 00 second).

### To check the remaining time of the sleep timer

Press SLEEP. The remaining time is displayed.

### Note

When the remaining time display returns to the function display, the function display is dimly lit on the display.

# Selecting a Program Source

## Labeling the Program Source

You can input program sources except TUNER under index names you create (up to 9 characters); for example, PHONO, CD etc.

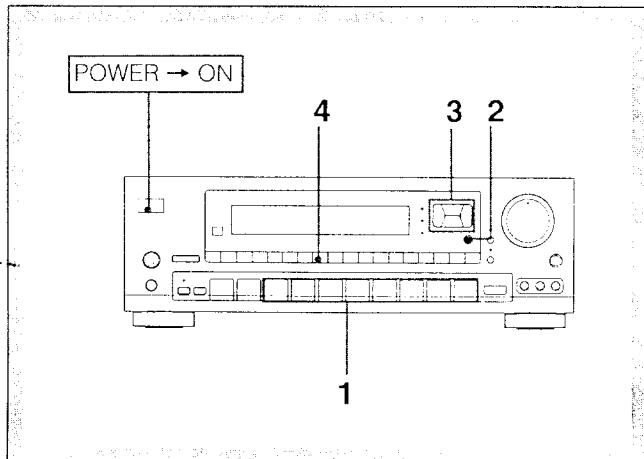

**1** Select the program source with the **FUNCTION** buttons.

**2** Press **CURSOR MODE** to select the **INDEX** mode.

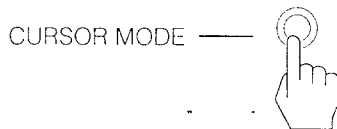

The **INDEX** indicator lights up.

**3** Create an index name.

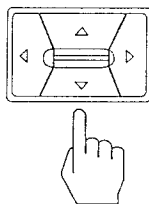

To select a letter, press  $\Delta$  or  $\nabla$ .  
To change the position, press  $\triangleleft$  or  $\triangleright$ .

When pressing a **FUNCTION** button to be named, the same function name as the **FUNCTION** button is displayed.

**4** Press **MEMORY**.



The **MEMORY** indicator appears on the display and goes off when the memory is finished.

**5** Repeat steps 1 to 4 for all other program sources you want to assign an index name to.

**If you input an already stored source under any other index name**

Only the last selected index name will be valid. Each program source can be stored under only one index name.

**To clear the index name**

Turn off the **POWER** switch or select another program source.

**Usable letters and symbols**

!(space)→#←%&'()\*+,-./0123456789:;<=>?†ABCDE  
FGHIJKLMNOPQRSTUVWXYZ[ ]\_↓abcdefghijklmnopq  
rstuvwxyz



# Receiving Broadcasts

## Tuning in a Station Directly (Direct Tuning)

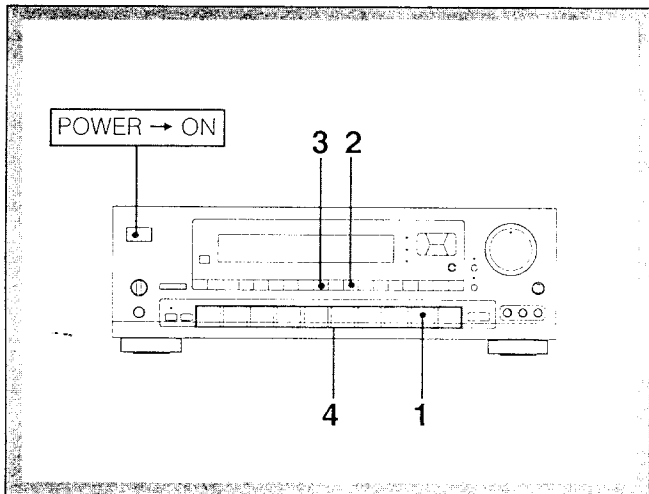

### 1 Press TUNER.

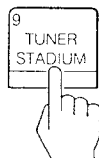

Frequency or the station index name you created is displayed.  
The FUNCTION buttons change to the numeric buttons.

### 2 Select FM or AM.



### 3 Press DIRECT TUNING.

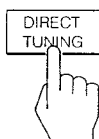

### 4 Enter the frequency with the numeric buttons.

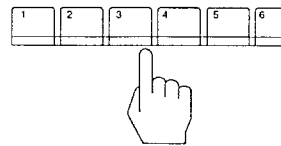

The entered frequency is displayed.

#### Example 1: FM 102.50 MHz

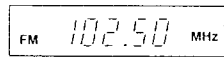
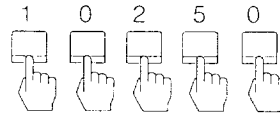

#### Example 2: AM 1350 kHz

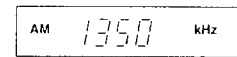
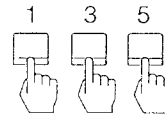

#### To correct the entered frequency

Repeat steps 3 to 4.

#### For entering AM frequencies

You need not enter the last "0".

However, if you have changed the AM tuning interval to 9 kHz, enter all the digits.

#### If you enter a frequency not covered by the tuning interval

The entered value is automatically rounded up or down to the closest value covered by the tuning interval.

Tuning intervals for direct tuning are the followings:

FM: 50 kHz interval

AM: 10 kHz interval (changeable to the 9 kHz interval)

(See page 5)

#### When the entered frequency does not exist in the receivable frequency range

The entered digits (up to 5 digits for FM or up to 3 digits for AM) blink in the frequency display area, and reception does not take place.

If this occurs, press DIRECT TUNING again, and enter the correct frequency (the frequency range of the receiver is 87.50 to 108.0 MHz for FM, and 530 to 1710 kHz for AM).

#### When an FM stereo program is noisy

When the unit receives an FM stereo program, the STEREO indicator lights on the display. If the stereo program is noisy, press FM MODE to change the mode over the MONO. This eliminates the stereo effect, but the noise will be greatly reduced.

To return to the stereo mode, press FM MODE again.

# Receiving Broadcasts

## Automatic Tuning

When you do not know the frequency of the station to be received, proceed as follows.

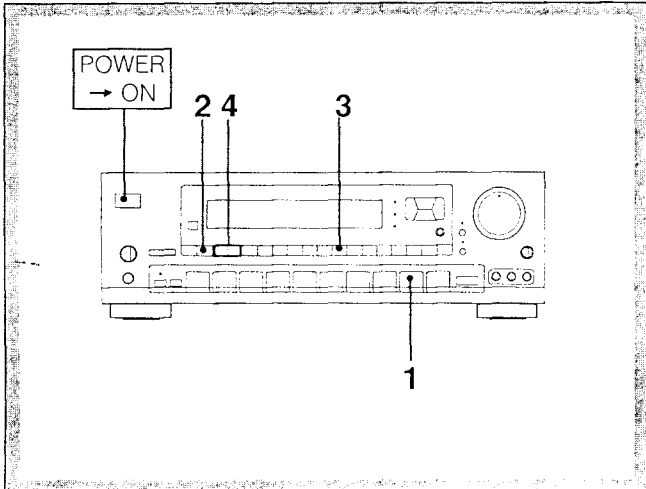

### 1 Press TUNER.

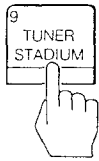

Frequency or the station index name you created is displayed.  
The FUNCTION buttons change to the numeric buttons.

### 2 When the index name is displayed, press DISPLAY INDEX to set to the FREQ mode.

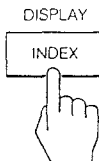

The frequency appears on the display.

### 3 Select FM or AM.



### 4 Press INDEX SELECT/TUNING – or + until the desired station is received..

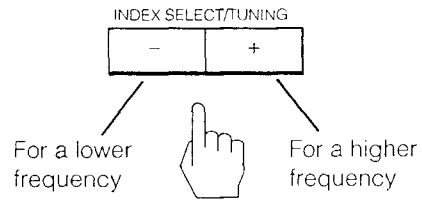

When a station is received, automatic tuning stops.

### If the automatic scan stops frequently (for FM reception only)

You can receive only the strong stations by pressing TUNING LEVEL. HIGH appears on the display.

### To receive all receivable stations again

Press TUNING LEVEL so that HIGH goes off.

## Presetting Stations (Station Preset)

A total of 30 FM/AM stations can be memorized in any desired sequence.

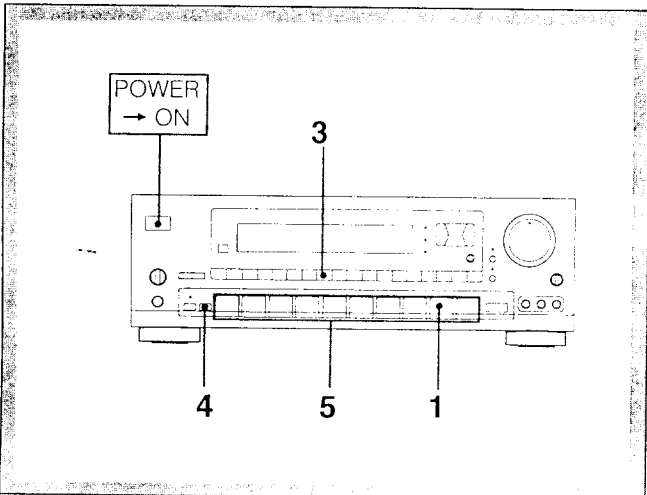

### 1 Press TUNER.

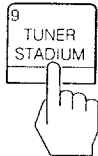

Frequency or the station index name you created is displayed.  
The FUNCTION buttons change to the numeric buttons.

### 2 Tune in the desired station.

(See "Direct Tuning" on page 17 or "Automatic Tuning" on page 18.)

### 3 Press MEMORY.

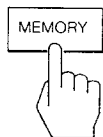

MEMORY appears on the display.

### 4 While MEMORY appears, select the memory page (A, B or C).



Each time SHIFT is pressed, A, B or C is indicated cyclically.

### 5 While MEMORY appears, press the desired number.

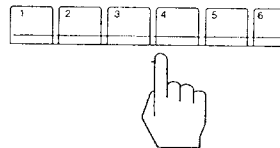

Repeat above steps for presetting other desired stations.

### Replacing a preset station

Preset another station on the number of the station to be replaced. The previously preset station will be erased.

## Labeling the Preset Stations (Station Index)

You can divide preset stations under index names you create (up to 5 characters). If you want to categorize the preset stations by kinds of music, for example, create indexes such as ROCK, JAZZ, etc.

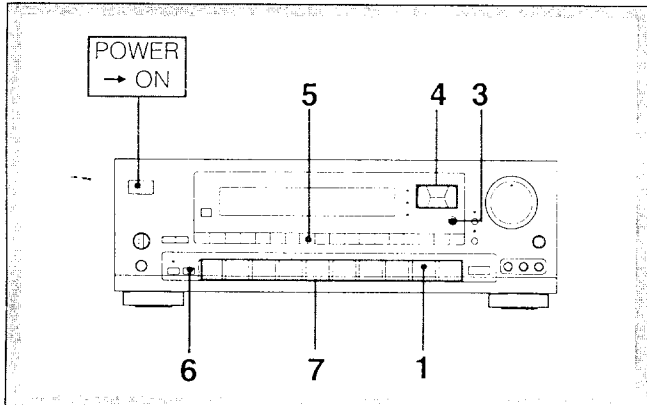

### 1 Press TUNER.

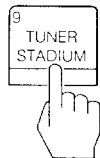

Frequency or the station index name you created is displayed.  
The FUNCTION buttons change to the numeric buttons.

### 2 Tune in the desired station with Preset Tuning on page 20.

### 3 Press CURSOR MODE to select the INDEX mode.

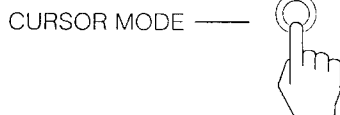

The INDEX indicator lights up.

### 4 Create an index name.

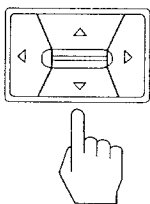

To select a letter or number, press  $\Delta$  or  $\nabla$ .  
To change the position, press  $\triangleleft$  or  $\triangleright$ .

### 5 Press MEMORY.

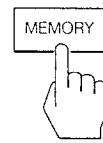

MEMORY appears on the display.

### 6 While MEMORY appears, select memory page (A, B or C).



### 7 While MEMORY appears, press the desired number.

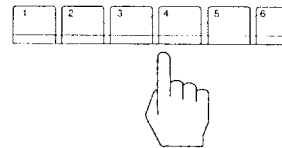

### 8 Repeat steps 2 through 7 for all other stations you want to assign an index name.

#### To clear the index name

Press TUNER in step 4.

#### When pressing TUNER in step 3 or 4

- The index name blinks and the index name you already created is displayed cyclically by pressing  $\Delta$  or  $\nabla$ .
- To designate the same index name as the one you already created, select the desired name by pressing  $\Delta$  or  $\nabla$  and then follow step 6.

#### If you store an already categorized station under any other index name

Only the last selected category will be valid. Each station can be stored under only one index name.

#### To display the frequency and index name of preset stations

Each time DISPLAY INDEX is pressed, frequency and index name of the preset station are alternately displayed.

#### Usable letters and symbols

!(space)→#←-%&'()\*+,-./0123456789:;<=>?↑ABCDE  
FGHIJKLMNOPQRSTUVWXYZ[ ]!\_↓abcdefghijklmnopq  
nopqrstuvwxyz

# Receiving Broadcasts

## Tuning in a Preset Station (Preset Tuning)

There are two ways to perform the preset tuning. In the method A, the direct tuning, select by designating the desired preset station number directly with the numeric button. In the method B, the scan tuning, select the preset station with the PRESET  $-/+$  button.

### Method A: Direct tuning

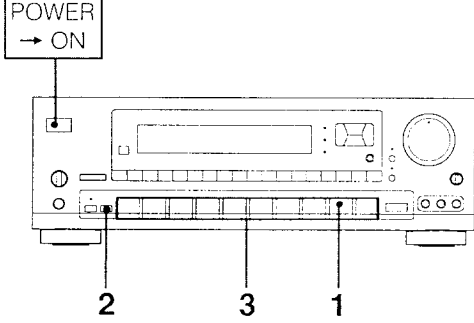

**1 Press TUNER.**

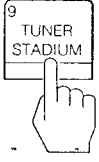

Frequency or the station index name you created is displayed.  
The FUNCTION buttons change to the numeric buttons.

**2 Select the memory page (A, B, or C).**



Each time SHIFT is pressed, A, B or C is indicated cyclically.

**3 Designate the desired preset station number with the numeric button.**

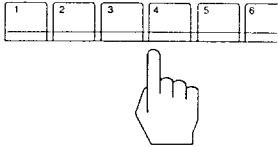

### Method B: Scan tuning

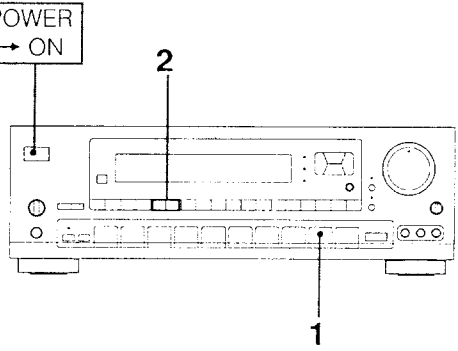

**1 Press TUNER.**



Frequency or the station index name you created is displayed.  
The FUNCTION buttons change to the numeric buttons.

**2 Select the desired preset station with PRESET TUNING  $-$  or  $+$ .**

PRESET TUNING

For a lower preset number  $-$  For a higher preset number  $+$

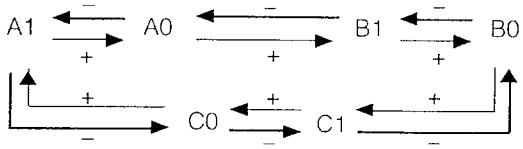

### IMPORTANT

The memorized station is maintained for approximately one month even if the power cord is disconnected from the AC power outlet. If they are erased, store the stations again.

# Receiving Broadcasts

## Selecting a Station among the Preset Stations in the Index (Index Tuning)

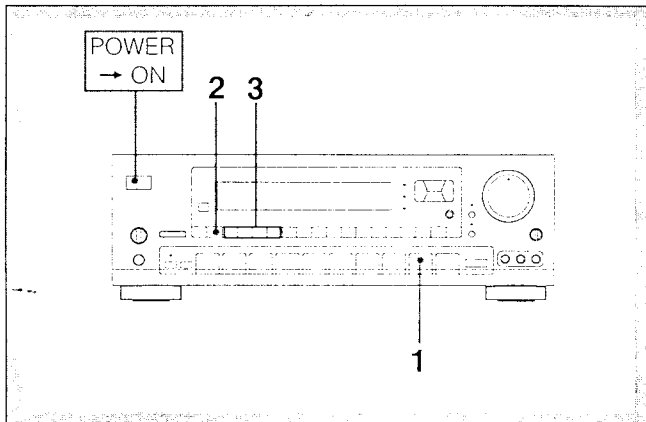

### 1 Press TUNER.

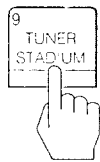

Frequency or the station index name you created is displayed.  
The FUNCTION buttons change to the numeric buttons.

### 2 Press DISPLAY INDEX to set to the INDEX mode.

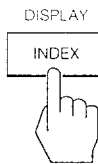

When the no index name is memorized, "-----" appears on the display.

### 3 Select the desired station.

- To select a station in the same index:

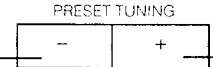
For lower channel index station  For higher channel index station

- To select a index station other than the displayed index station:

 For lower channel index station For higher channel index station

## Receiving FM Simulcast TV Programs

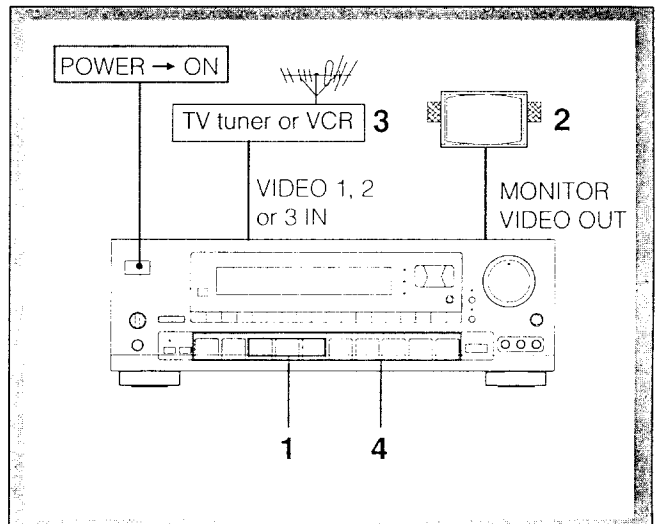

### 1 Select VIDEO 1, VIDEO 2 or VIDEO 3.

VIDEO 1, VIDEO 2 or VIDEO 3 appears on the display.  
According to video inputs connected to an equipment to which the VHF antenna is connected.

### 2 Turn on the monitor TV.

### 3 Select the desired program on the TV tuner or the VCR.

### 4 Select TUNER and tune in the FM simulcast TV program on the receiver.

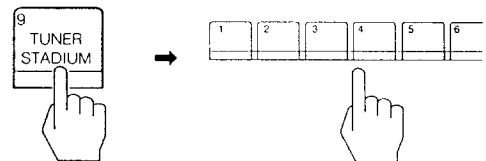

# Selecting a Factory-preset Sound Effects

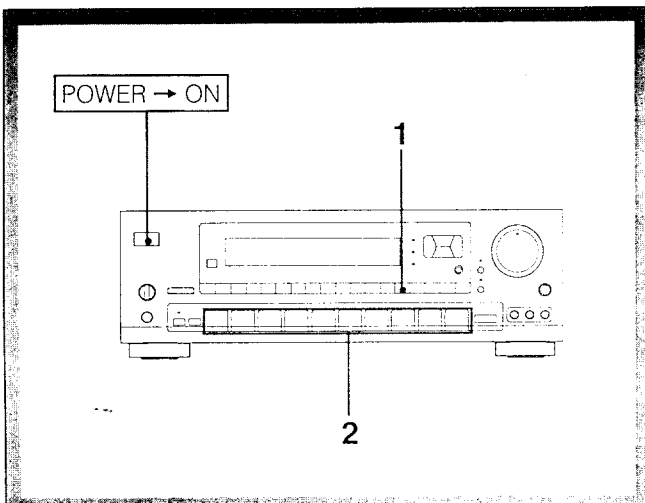

**1** Press **USER/PRESET**.  
PRESET appears on the display.

**2** Press the desired **SOUND FIELD**.

SOUND FIELD	Applications
<b>DOLBY SUR</b>	For Dolby surround encoded video programs
<b>THEATER</b>	For movie programs on video tapes or laser discs
<b>LIVE</b>	For music programs on video tapes or laser discs
<b>HALL</b>	For orchestral music, chamber music or an instrumental solo
<b>DANCE</b>	For dance music
<b>JAZZ</b>	For jazz
<b>OPERA</b>	For operas or musicals
<b>CHURCH</b>	For church music or the pipe organ
<b>STADIUM</b>	For live concert in an open-air stadium
<b>ACOUSTIC</b>	The surround effect is defeated and only the equalizer effect can be obtained.

Refer to page 28 for the characteristic of each mode.

# Recording an Audio Source

## Recording onto an Audio Tape Deck or DAT Deck

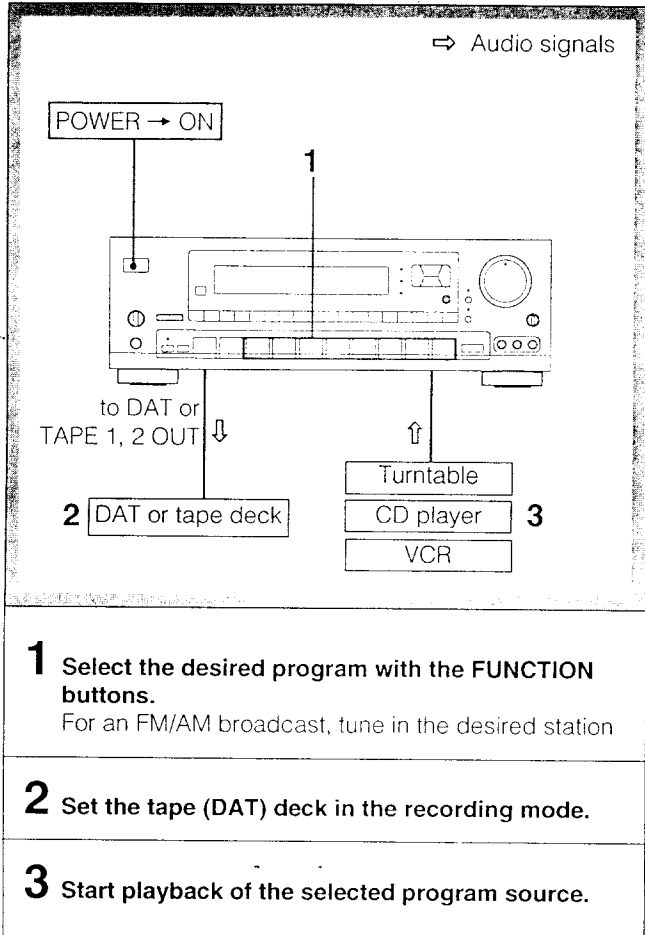

### Monitoring the recorded sound

If you have connected a 3-head tape deck to the TAPE 2 jacks, you can monitor the recording results. While recording or dubbing, press TAPE 2 MONITOR so that the TAPE 2 MONITOR indicator lights up. To listen to the source sound again, press the button again so that the indicator goes off.

## Tape Dubbing

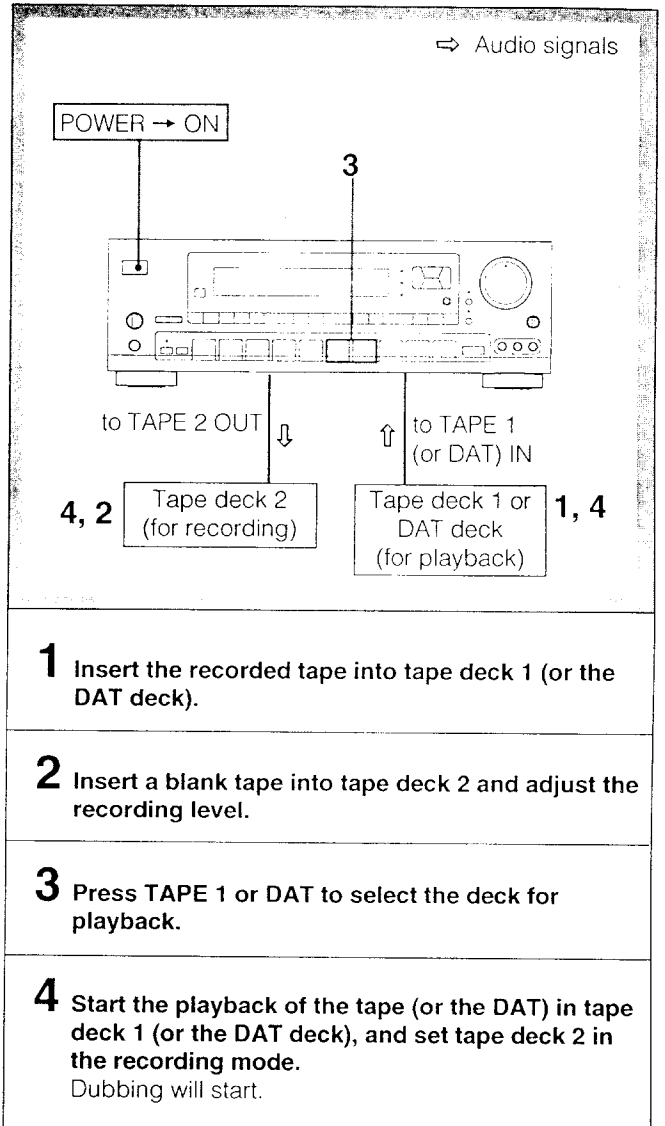

### Note on tape dubbing

Tape dubbing is possible only in the following directions:

From (playback deck)	To (Recording deck)
Tape deck connected to TAPE 1 IN	Tape deck connected to TAPE 2 OUT
	DAT deck connected to DAT OUT
DAT deck connected to DAT IN	Tape deck connected to TAPE 1 or 2 OUT

Press the **FUNCTION** buttons according to the playback deck.



# Editing a Video Source

## Video Tape Dubbing

If the AUDIO indicator is lit on the display, press the EDIT AUDIO button to make the indicator go out.

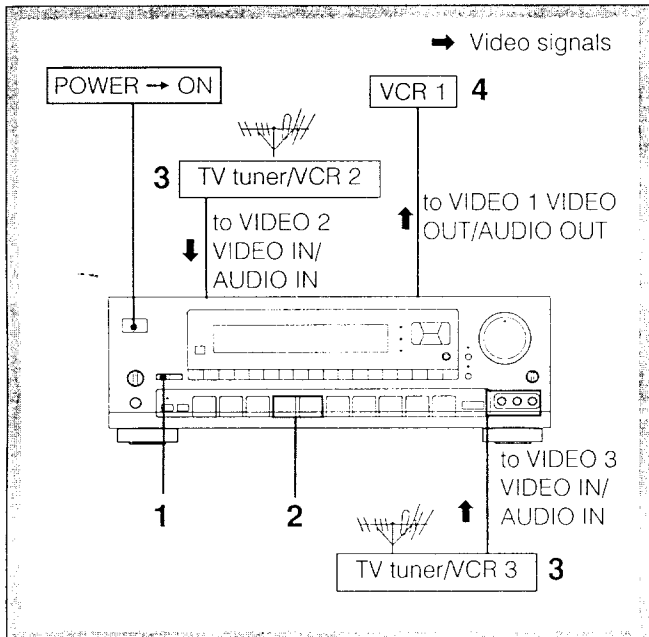

**1 Select the playback VCR with EDIT VIDEO.**  
To select VCR 2, press EDIT VIDEO so that "2> 1" appears on the display.  
To select VCR 3, press EDIT VIDEO so that "3> 1" appears on the display.

**2 Press VIDEO 2 or VIDEO 3 to select the video signal to monitor on the monitor TV according to the VCR to be played.**  
VIDEO 2: for the VCR 2  
VIDEO 3: for the VCR 3

**3 Set the playback VCR to the playback mode.**

**4 Set the VCR 1 to the recording mode.**  
Dubbing will start.

## — Video Tape Editing —

### To switch the playback VCR during dubbing

Press EDIT VIDEO. Each time you press the button, the playback VCR switches from the VCR 2 to the VCR 3 (or the VCR 3 to the VCR 2).

### To view the other video source(s) on the monitor TV during dubbing

Press the appropriate function selector, VIDEO 1, VIDEO 2, or VIDEO 3.

### To listen to an audio program during video tape dubbing

- 1 Press the appropriate function selector.
- 2 Start the selected audio program source.

# Editing a Video Source

## Adding New Sound on a Video Tape during Video Editing

During video tape editing, you can add the desired sound on the recording VCR from various audio program sources.

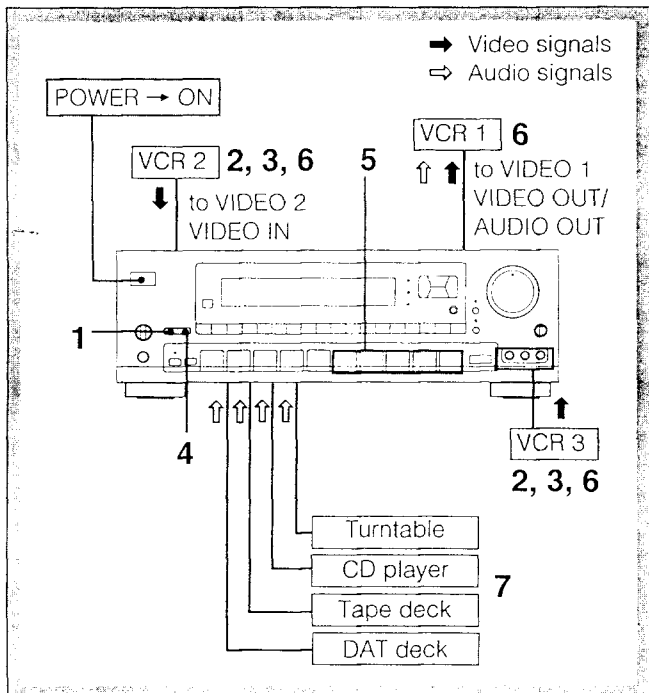

- 1 Select the playback VCR with EDIT VIDEO.**  
 To select VCR 2, press EDIT VIDEO so that "2> 1" appears on the display.  
 To select VCR 3, press EDIT VIDEO so that "3> 1" appears on the display.

- 2 Set the playback VCR to the playback mode.**

- 3 At the point where audio dubbing starts, press the pause button on the playback VCR.**

- 4 Press EDIT AUDIO.**

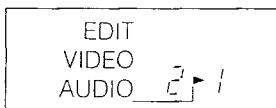

AUDIO appears on the display.

- 5 Select the audio program source.**

- 6 Release the pause mode of the playback VCR and set the VCR 1 to the recording mode.**

- 7 Start playback of the selected audio program source.**  
 Video dubbing starts and the audio program source is also recorded on the VCR 1 simultaneously.

# What Is the Digital Signal Processor ?

The STR-D1011 incorporates digital signal processing circuitry which consists of a digital surround processor and a digital parametric equalizer.

- The digital surround processor electronically reproduces the acoustics of various listening situations.
- The digital parametric equalizer controls the output level of specific frequencies to finely adjust the frequency responses.

These 2 digital sound effects allow you to create the optimum sound quality and sound atmosphere in your room.

10 recommended sound field programs (combination of settings of the surround and parametric equalizer have been preset in the factory. Since these programs are appropriate for the most types of music and listening situations, you can enjoy the digital sound effects by just selecting the sound field programs according to the program source. And you can also manipulate various parameters to finely tune the factory-preset settings to your room, or create original sound effects as you like. (Pages 32 to 37)

This manual described about the sound field program in the following order:

Surround effect

Digital parametric equalizer

Storing your private sound field program

# Sound Field Setting

## Table of Adjustable Parameters

The surround sound and digital parametric equalizer have each adjustable parameter.

Parameter		SOUND FIELD									
		DOLBY SUR	THE-ATER	LIVE	HALL	DANCE	JAZZ	OPERA	CHURCH	STADIUM	ACOUS-TIC
Equalizer		○	○	○	○	○	○	○	○	○	○
Room size		X	○	○	○	○	○	○	○	○	X
Surround sound	Wall	X	○	○	○	○	○	○	○	○	X
	Seat position front/rear	X	○	○	○	○	○	○	○	○	X
	Seat position left/right	X	○	○	○	○	○	○	○	○	X
	Effect level	X	○	○	○	○	○	○	○	○	X
	Reverb time	X	○	○	○	○	○	○	○	○	X
	Delay time	○	X	X	X	X	X	X	X	X	X
	Rear level	○	○	○	○	○	○	○	○	○	X
	Center level	○	○	○	X	X	X	X	X	X	X

Refer to pages 30 to 36 for adjusting these parameter.

# Getting Ready for Dolby Surround Sound

This section describes about selecting the speaker configuration and then adjusting the speaker volume and the delay time of the rear speakers so that you can enjoy the Dolby surround sound.

## Placement of Speakers and Selecting the PRO LOGIC MODE

The Dolby Pro Logic Surround Decoder has the same functions for playback, such as movie theaters and gives a theater-like experience in your listening room, naturally reproducing the audio sound field.

The STR-D1011 incorporates a decoder which reproduces the specially encoded surround sound of Dolby surround video programs.

In the Dolby surround mode, select the speaker operation mode according to your speaker configuration by pressing the DOLBY PRO LOGIC MODE button. Each time the DOLBY PRO LOGIC MODE button is pressed, the DOLBY PRO LOGIC MODE is changed in the following order:

→ NORMAL → WIDE → PHANTOM → 3 CH. LOGIC

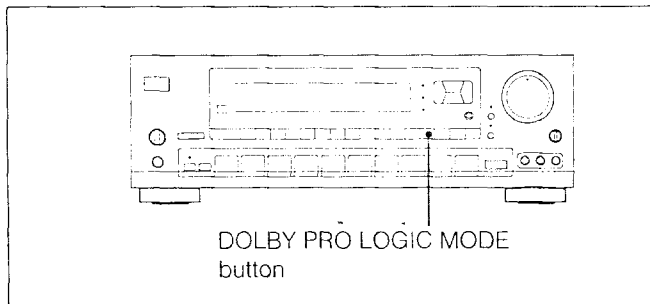

### NORMAL mode

Select this mode if you use a small center speaker. The bass sound of the center channel is output from the front speakers, as a small speaker cannot produce enough bass.

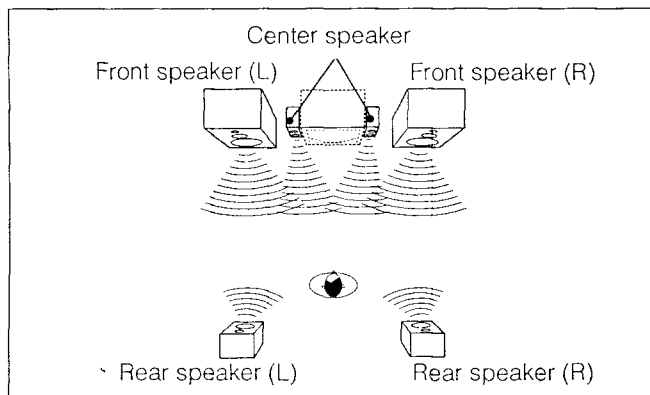

### WIDE mode

Select this mode if you use a medium to big center speaker.

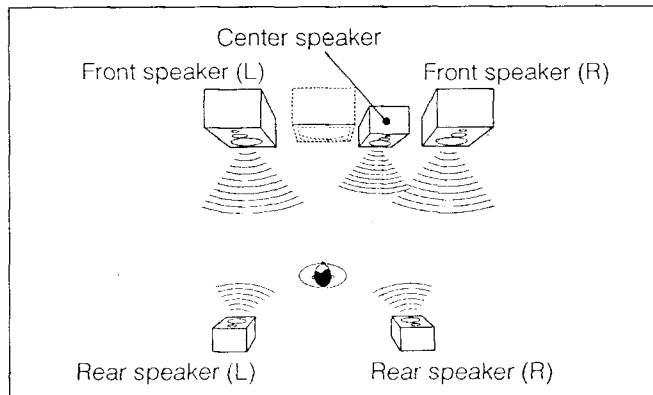

### PHANTOM mode

Select this mode when you play back a Dolby surround program source without using a center speaker. The sound of the center channel is output from the front (L and R) speakers.

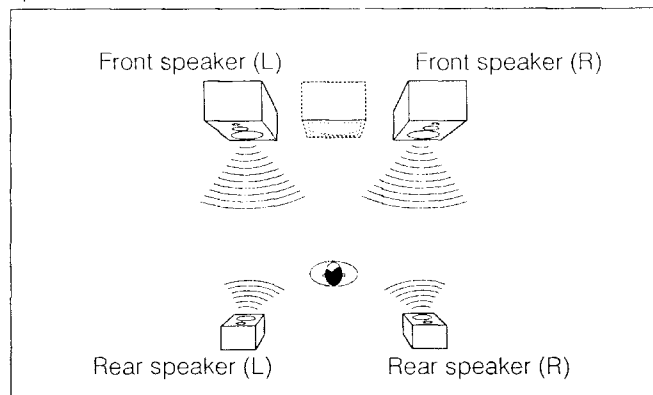

### 3CH. (Channel) LOGIC mode

Select this mode when you play back a Dolby surround program source only with the front and center speakers. The sound of the rear channel is output from the front (L and R) speakers.

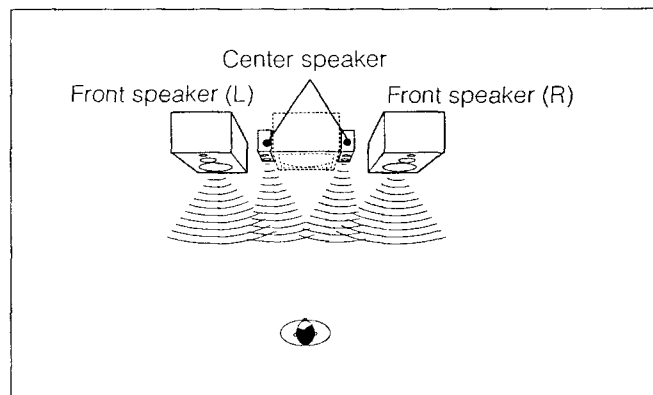

### Note

Some commercially available software may have Dolby surround processed sound tracks even though it is not so indicated on the package.

# Getting Ready for Dolby Surround Sound

## Adjusting the Speaker Volume

To enjoy the surround sound to the maximum on playing any program sources, adjust the front, center, and rear (if connected) speakers to the same volume level. The adjustment must be done with a test tone in the DOLBY SUR mode, but the level once adjusted can be used for all surround modes.

You can adjust the volume level from your listening position by using the remote commander.

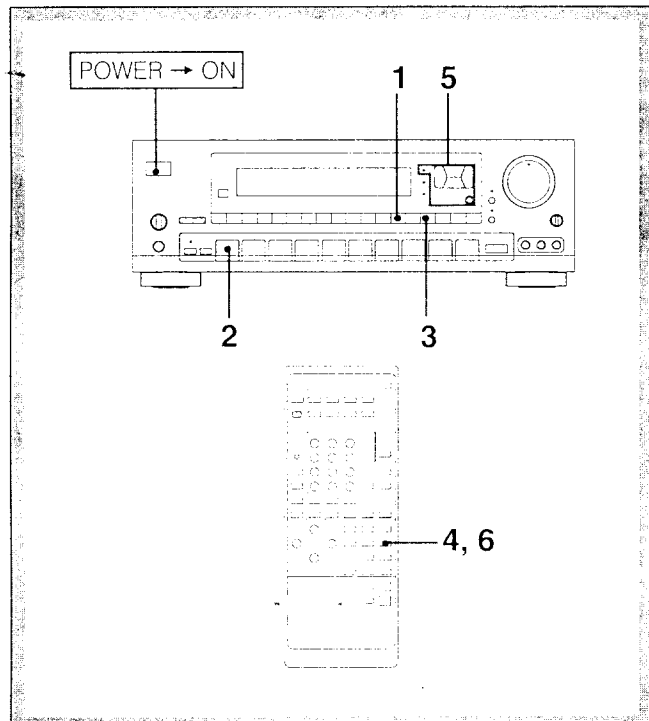

**1 Press SOUND FIELD ON/OFF to ON.**  
The indicator of the last selected sound field lights up.

**2 Press DOLBY SUR.**  
DOLBY SUR appears on the display.

**3 Select the Dolby pro logic mode with the DOLBY PRO LOGIC MODE button according to your speaker system.**

**4 Press T. TONE on the remote commander to set to on.**

**5 Press CURSOR MODE.**  
The SUR (surround) indicator lights up.

**To adjust the level of center speakers**  
Press  $\Delta$  or  $\nabla$  to select the center level mode and then adjust the level with  $\triangleleft$  or  $\triangleright$  or CENTER LEVEL +/- on the remote commander so that sound from each speaker is heard in the same volume level at the listening position. (When adjusting the VOLUME control on the receiver, all speakers are adjusted simultaneously.)

**To adjust the level of rear speakers**  
Press  $\Delta$  or  $\nabla$  to select the rear level mode and then adjust the level with  $\triangleleft$  or  $\triangleright$  or REAR LEVEL +/- on the remote commander.

**6 Press T. TONE on the remote commander to set to off.**

### Sequence of the test tone

In a system with a center speaker:

The test tone will be output automatically from the front L, center, front R, and the rear speakers in succession.

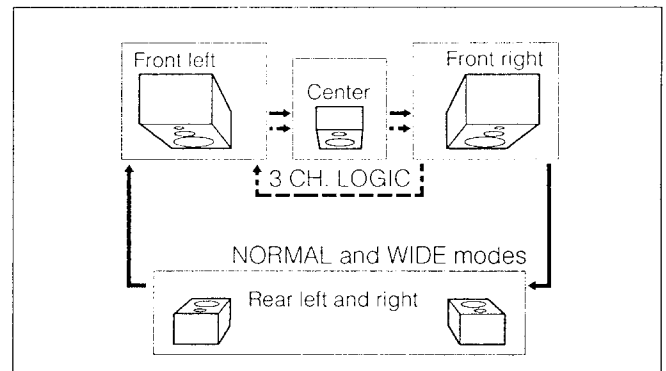

In a system without a center speaker:

The test tone will be output automatically from the front left and right speakers and the rear speakers alternately.

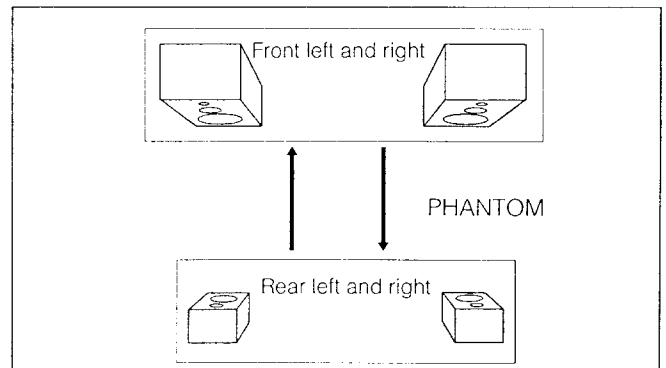

## Adjusting the Delay Time of the Rear Speakers

### — for Dolby surround mode

The delay time is a time between the surround sound from the front and that from rear speakers. The delay time is adjustable from 15 ms to 30 ms.

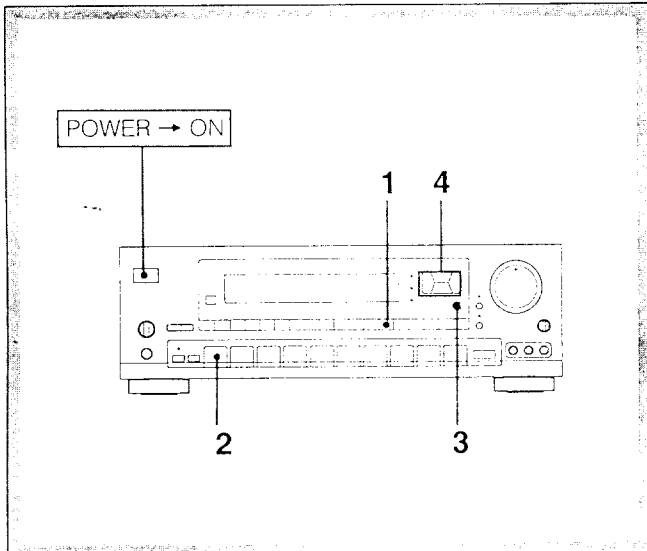

**1** Press **SOUND FIELD ON/OFF** to ON.  
The last selected sound field is displayed in box.

**2** Press **DOLBY SUR**.  
DOLBY SUR appears on the display.

**3** Press **CURSOR MODE**.  
The SUR (surround) indicator lights up.

**4** Press  $\Delta$  or  $\nabla$  to select the delay time mode and adjust the delay time with  $\triangleleft$  or  $\triangleright$ .

### To turn off the surround effect

Press **SOUND FIELD ON/OFF** to OFF.  
The normal sound without surround and equalizer effect will resume.

### To memorize the speaker volume and the delay time of the rear speakers

Press **USER/PRESET** to set to the **USER** mode and then adjust the speaker volume and delay time with the cursor operation buttons.

# Adjusting the SOUND FIELD program

## Understanding the Digital Surround Processor

The sound heard in a place such as a concert hall or a movie theater consists of direct sound, and early reflected sound (early reflections) and a reverberative sound (reverberation). The acoustics of the room affect the way these three sounds are heard. We can estimate the size or the type of a hall by listening to and differentiating these three kinds of sound.

The STR-D1011 reproduces the early reflections and the reverberation using its digital signal processor and allows you to design a variety of sound field in your own room. The unit incorporates 10 types of the SOUND FIELD program, and you can select the desired SOUND FIELD mode by pressing the SOUND FIELD button. Also you can adjust several parameters within each mode to maximize the effect in your listening room.

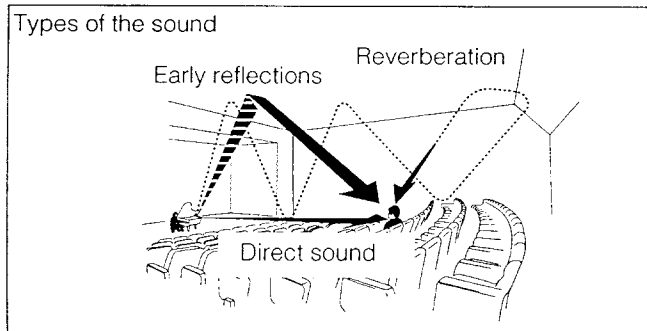

The sound transition of the direct sound, early reflections and reverberation can be illustrated as below:

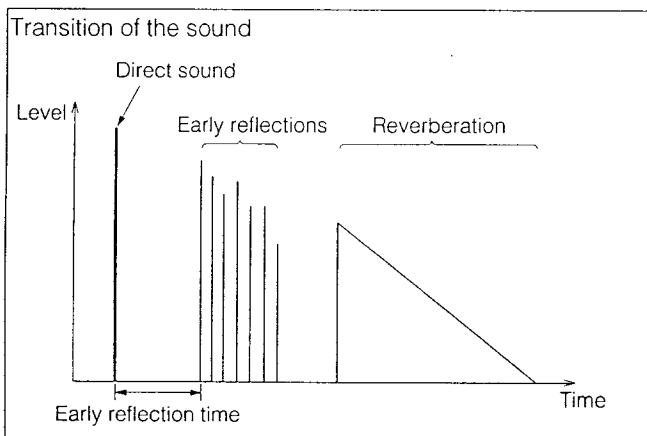

### Note

Each surround mode has several internal (fixed) parameters in addition to the adjustable parameters explained in this section. Therefore, surround modes will not become the same even if you set all adjustable parameters the same.

## Characteristics of the SOUND FIELD program

SOUND FIELD	Characteristics	Appropriate music source
DOLBY SUR	Decodes programs processed with the Dolby surround.	Dolby surround processed software
THEATER	Adds the reflection of a theater to decoded signals of the Dolby prologic decoder.	Dolby surround processed movie software
LIVE	Adds the reflection of a large concert hall to decoded signals of the Dolby prologic decoder.	Dolby surround processed music software
HALL	Reproduces the acoustics of a rectangular concert hall with soft sound. It is effective for playing a program source with hard sound.	Solo, medium-size orchestra or classic
DANCE	The equalizer boosts high and low frequencies, and the dynamic sounds are reproduced.	Pops or dance music
JAZZ	Reproduces the acoustics of a live house. The equalizer boosts high frequencies, adding sharpness to sounds.	Jazz
OPERA	Reproduces the acoustics of an opera house, keeping the clearness of the vocal music.	Opera
CHURCH	Reproduces the acoustics of a church made of wood	Baroque music, string orchestra or choral group
STADIUM	Reproduces the acoustics of an outdoor stadium with a long pre-delay time. It is effective for playing a program source recorded in a stadium.	Pops or rock music
ACOUSTIC	The surround effect is defeated.	



## Adjusting the Surround Effect

Before adjusting parameters, play back the program source. You can adjust parameters while listening to the actual sound.

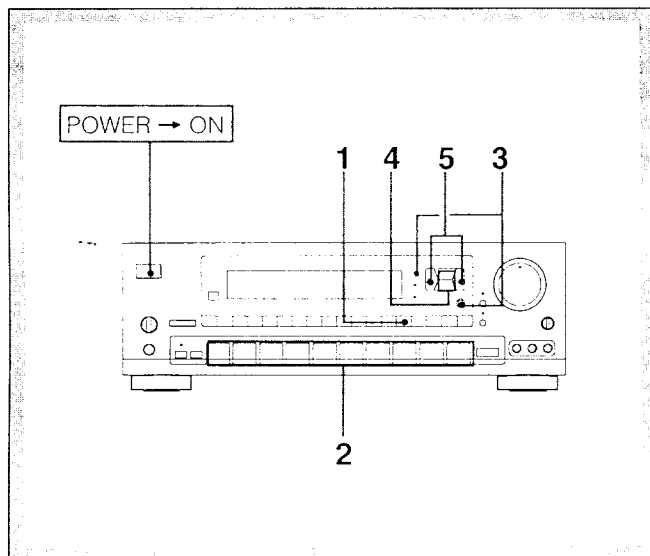

**1** Press **USER/PRESET** to set to the **USER** mode when you store your private setting or to set to the **PRESET** mode when you do not store your setting.

**2** Press the desired **SOUND FIELD** program.

**3** Press **CURSOR MODE** to select the **SUR (surround) mode**.  
The **SUR** (surround) indicator lights up.

**4** Press **Δ** or **▽** to select the desired parameter.

**5** Adjust the parameter by pressing **◀** or **▶**.

### Tips for adjusting the main parameters

The following procedure allows you to make the desired sound field more effectively.

- 1 Select the desired factory-preset sound field program.
- 2 Adjust the effect level.
- 3 Adjust the reverberation time.
- 4 Adjust other parameters, if necessary.

### When you store a new **SOUND FIELD** effect

The previous **SOUND FIELD** effect is erased and the new one will be replaced.

### Even if **AC power cord** is disconnected

The stored data is maintained for approximately 1 month.

### When selecting **ACOUSTIC**

**ACOUSTIC** does not have the surround effect and only the equalizer effect can be available. So when selecting **ACOUSTIC**, only the setting of parametric equalizer can be adjusted.

# Adjusting the SOUND FIELD program

## ■ Room Size Simulation

The sound emitted from a sound source is reflected many times between the left and right walls, ceiling, and floor before it reaches our ears. In a large room, the sound takes more time to bounce from one surface to another than in a smaller room.

The ROOM parameter controls the spacing of early reflections to simulate the room size. The S indicator on the display signifies a small room, the L indicator signifies a large room and the middle point designates the standard room size.

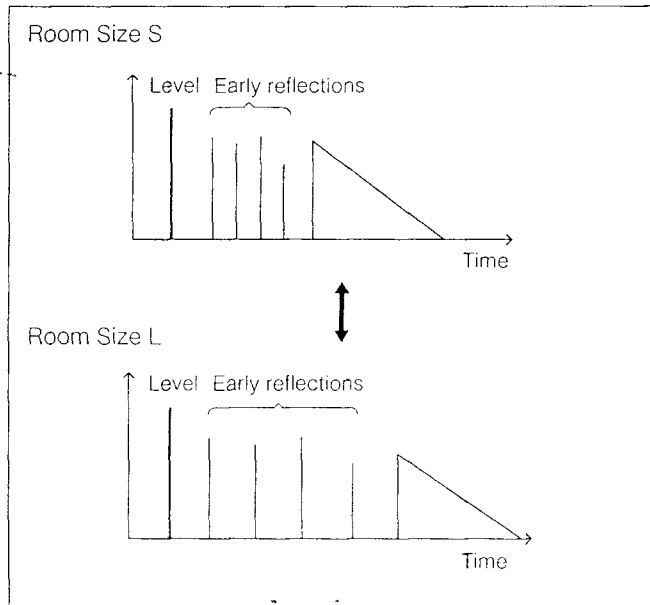

## ■ Wall Material Simulation

When sound is reflected by a wall made of soft material such as wood or a wall covered with a curtain, the high frequency components are reduced. A hard wall is highly reflective and does not significantly effect the frequency response of the reflected sound.

The WALL parameter controls the level of high frequencies to simulate the wall material. The S indicator on the display signifies a soft wall, the H indicator signifies a hard wall, the middle point designates the standard wall made of wood.

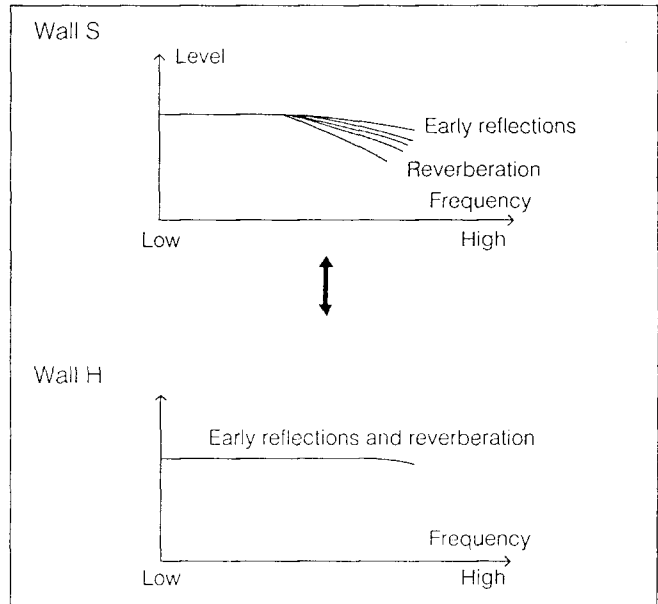

■ **Seat Position Simulation**

When you sit in the front of a room, you will hear more direct sound from the front speakers, and the component of reflected sounds from the front speakers grows as you move to the rear. Similarly, the component of reflected sound changes when you move from left to right, and vice versa. The F/R and L/R parameters control the balance of the direct and reflected sound and other components of sound to simulate your listening position.

When adjusting the F/R parameter, the F indicator on the display signifies the front position of the room, the R indicator signifies the rear position, the middle point of the indicator designates the center position. When adjusting the L/R parameter, the L indicator signifies the left position of the room, the R indicator signifies the right position, and the middle point of the indicator designates the center position.

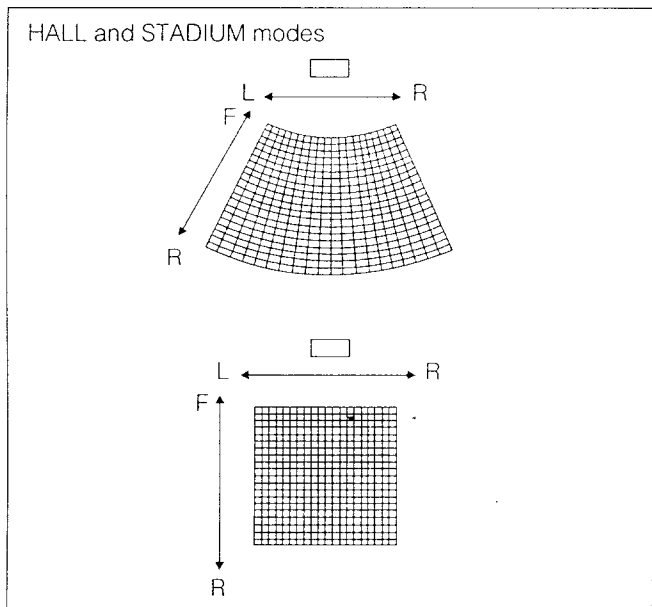

■ **Effect Level**

Effect level is the combination of the level of early reflections and reverberation. The L indicator on the display signifies the lowest level and the H indicator signifies the highest level. The adjustable level is divided into 20 segments. As you select higher level, the room becomes more "live", and as you select lower level, the room becomes "dead".

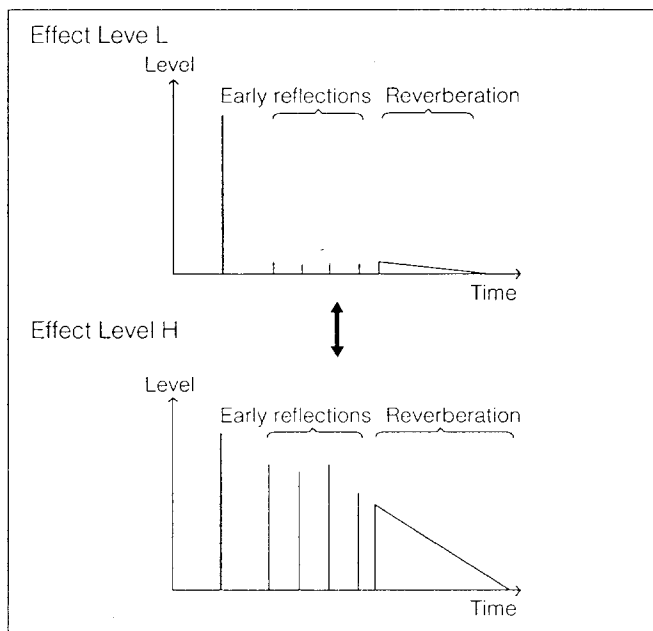

■ **Reverberation Time**

This parameter adjusts the length of the reverberation — the time required for reverberative sound to decrease to -60 dB. The S indicator on the display signifies the shortest reverberation time, the L indicator signifies the longest reverberation time.

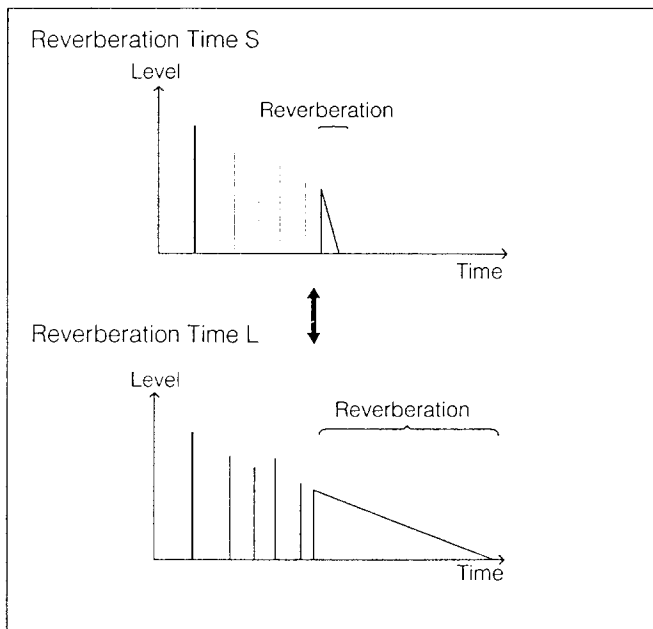

# Adjusting the SOUND FIELD program

## Understanding the Digital Parametric Equalizer

The parametric equalizer is a tone control system with adjustable center frequency and slope (Q). The STR-D1011 provides flexible equalization using one-band parametric equalizer with center frequency and slope, and 2-band shelving equalizers with adjustable turnover points.

The equalization curve appearing on the display allows you to accurately adjust the sound quality. The parametric equalizer effects all line output signals including SURROUND (REAR, CENTER).

## How to Adjust the Digital Parametric Equalizer

Before adjusting the digital parametric equalizers, play back the program source. You can adjust the equalizer while listening to the actual sound.

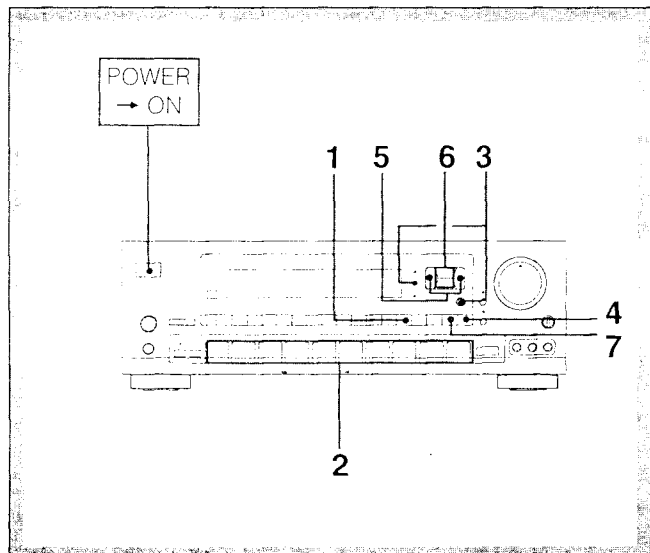

**1** Press **USER/PRESET** to set to the **USER** mode when you store your private setting or to set to the **PRESET** mode when you do not store your setting.

**2** Press the desired **SOUND FIELD** program.

**3** Press **CURSOR MODE** to select the **EQ (equalizer)** mode.  
The **EQ (equalizer)** indicator lights up.

**4** Press **EQUALIZER BAND** to select a frequency band.  
**B:** Bass  
**M:** Middle  
**T:** Treble

**5** Press **◀** or **▶** to select the frequency you want to adjust.

**6** Press **△** or **▽** to raise or lower the level of the selected frequency.

**7** Adjust the frequency level of the mid range by pressing **EQUALIZER SLOPE** if necessary.

**8** Repeat steps 4 through 7 for other frequency bands until you obtain the desired equalization curve.

### To make the equalization curve flat

Press **EQUALIZER FLAT**.

You can create a new equalization curve.

### On the function of **DISPLAY GRAPHIC**

Every time you press **DISPLAY GRAPHIC**, the display of equalizer curve, real time analyzer and peak hold is cyclically switched. Each display shows as followings. In the **DOLBY SUR**, **LIVE** or **THEATER** mode, the levels of each channel are graphically displayed except when the equalizer curve is displayed.

- Equalizer curve shows the settings of the equalizer controls.
- Real time analyzer (RTA type-1) shows the level of each frequency range.  
In the **DOLBY SUR**, **LIVE** or **THEATER** mode, the levels of each channel are displayed.
- Peak hold mode (RTA type-2) shows that this mode holds the highest input of each frequency range for several seconds.  
In the **DOLBY SUR**, **LIVE** or **THEATER** mode, peak levels of each channel are held for several seconds.
- Real time analyzer (RTA type-3) shows the highest level of each frequency range.  
In the **DOLBY SUR**, **LIVE** or **THEATER** mode, the highest levels of each channel are displayed.

### When the center frequency band overlaps the bass or treble frequency band during adjustment

The setting level of each band will accumulate.

The equalization curve appears only between  $\pm 10$  dB.

# Enjoying with Your Private Setting

## Calling up the Sound Field Setting

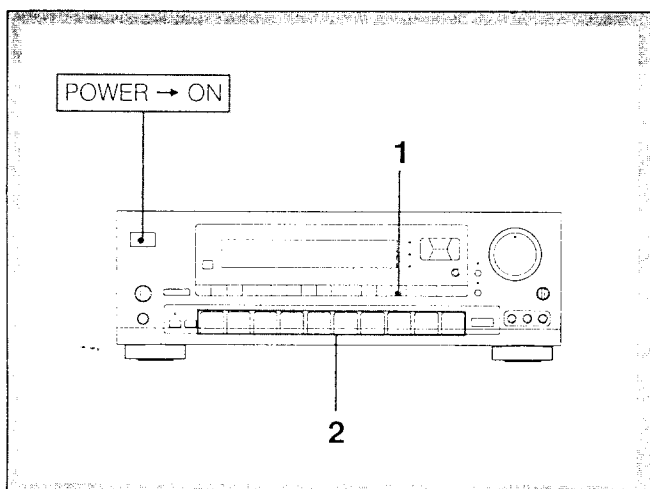

**1** Press **USER/PRESET** to set to the **USER** mode when you call up your private setting or to set to the **PRESET** mode when you call up the factory preset setting.

**2** Press the desired **SOUND FIELD** program.

## Linking the Sound Field Memory to Preset Stations or Program Sources

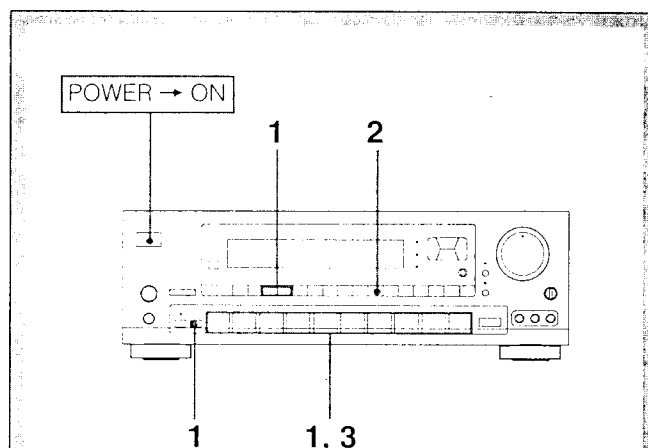

**1** Tune in a station or select the program source to be linked with sound field data.

**2** Press **SOUND FIELD LINK**.

**3** Press the desired **SOUND FIELD** program.

### Notes

- When other sound field is selected in the LINK mode, the previous sound field setting linked with the preset station or program source is replaced with the newly selected one. Therefore, if you want to select other sound field without changing the sound field setting in memory, press LINK to turn off the LINK mode and then select other sound field.
- When the sound field setting is adjusted, the sound field setting linked with the preset station or program source is also changed.

# Troubleshooting Guide

Before proceeding through the check list below, examine the connections and the procedures outlined in the manual.  
Should any problem persist after you have checked the following items, consult your nearest Sony dealer.

Problem	Cause	Solution
No FM station can be located by Automatic tuning operation.	The signal strength of the stations is too weak.	Press TUNING LEVEL to set the receiving signal level low. Check the antenna connection.
The STEREO indicator flickers or does not appear when receiving stereo programs.	A very weak FM station or a noisy FM program is received.	Adjust the antenna or connect an external FM antenna. Press FM MODE to set to MONO mode.
No station can be tuned in by Automatic tuning operation.	The AM tuning interval is set incorrectly.	Change the tuning interval according to the AM frequency allocation system of your country. (See page 5)
	The signal strength of the station is too weak for Automatic tuning.	Adjust the antenna. Directly tune in the stations. (See page 17)
No stations can be tuned in by pressing PRESET TUNING +/-.	No stations have been preset.	Preset the stations. (See page 19)
No sound is heard even if you adjust VOLUME.	The speaker or program source equipment is not connected correctly.	Connect the equipment correctly.
	The SPEAKERS selector is not set correctly.	Set the selector correctly. (See page 14)
	TAPE 2 has been pressed for a program source other than tape deck 2. (The indicator is lit.)	Press the button to disengage.
	A wrong function selector has been pressed.	Press the correct function selector.
	The function switch on the VCR is not set correctly.	Check and set it correctly.
No sound or sound at very low level is heard from rear speakers.	SOUND FIELD function is turned off.	Press SOUND FIELD ON/OFF to turn on the function.
	Monaural program source is played back in Dolby surround mode.	Select the other modes.
Sound is heard only at a very low volume.	MUTING has been pressed. (The MUTING indicator is lit.)	Press the button to disengage.
One channel does not transmit audio, or the volume from the left and right speakers is unbalanced.	The BALANCE control is not set appropriately.	Adjust the BALANCE control.
	The speaker or program source is not connected correctly.	Check and properly connect the equipment.
There is an abrupt loss of sound from one or both of the speakers, and the PROTECTOR indicator flickers on the display.	A short-circuit problem activates the protective circuit.	Turn off the unit, eliminate the short-circuit problem and turn on the power again. If there is no short-circuit problem, consult your nearest Sony dealer.

Problem	Cause	Solution
Sound transmitted from the speakers is reversed.	The speakers are not connected correctly.	Connect the right speaker to the R SPEAKER terminals and the left speaker to the L SPEAKER terminals.
There is lack of bass sound or the instrument position is obscure.	The  connection of the speaker is reversed.	Connect the speaker with the correct phase.
Severe hum or noise is heard.	The connecting cords are not shielded type.	Use shielded type cords.
	A transformer, motor, TV or fluorescent light affects the connecting cords.	Place the connecting cords in a location away from a transformer or motor, and at least 3 meters (10 feet) from a TV set or a fluorescent light.
	The audio components are too close to a TV set.	If both are used at the same time, separate the TV from the audio components.
	The unit is not grounded.	Connect the ground wire to the antenna ground terminal.
	The connections are loose.	Make secure connections.
Surround effect cannot be obtained.	The plugs and jacks are dirty.	Wipe the plugs and jacks with a cloth lightly dampened with alcohol.
	The unit is in a wrong mode.	Press CURSOR MODE to set the SUR (surround) mode.
	Surround circuit is turned off.	Set the FUNCTION/SOUND FIELD/PRESET TUNING buttons to the SOUND FIELD mode and select an appropriate SOUND FIELD.
Equalization curve adjustment is impossible.	The unit is in a wrong mode.	Press CURSOR MODE to set the EQ (equalizer) mode.
	Equalization circuit is turned off.	Set the FUNCTION/SOUND FIELD/PRESET TUNING buttons to the SOUND FIELD mode and select an appropriate SOUND FIELD.
The FUNCTION buttons do not change to the SOUND FIELD buttons even after pressing one of the FUNCTION buttons except TUNER or these buttons do not change to the numeric buttons even after pressing TUNER.	The FUNCTION/SOUND FIELD/PRESET TUNING buttons are set to the manual mode.	Set to the auto mode. (See page 9)
The remote commander will not operate.	The batteries are exhausted.	Replace the batteries with new ones.
	The commander head is not pointed toward the unit's front.	Point the commander head toward the receiver.
The equipment cannot be operated by using the remote commander.	There is an object between the commander and the receiver.	Remove the object.
	The mode of the receiver is not same with that of the remote commander.	Press the desired FUNCTION button again.

# Specifications

## Audio Power Specifications

### POWER OUTPUT AND TOTAL HARMONIC DISTORTION

With 8-ohm load, both channels driven, from 20 - 20,000 Hz, rated 120 watts per channel minimum RMS power, with no more than 0.04 % total harmonic distortion from 250 milliwatts to rated output.

	Surround mode (8 ohms)
FRONT (at 1 kHz)	80 W/ch
CENTER* (at 1 kHz)	80 W
REAR (at 1 kHz)	30 W/ch

\* (only in the DOLBY SUR, THEATER and LIVE modes)

## Other Specifications

### Amplifier section (Front)

Continuous RMS power output (8 ohms, at 20 Hz-20 kHz)  
130 W + 130 W

Dynamic power output (in the stereo mode)	8 ohms, at 1 kHz IHF	185 W + 185 W
	4 ohms, at 1 kHz IHF	235 W + 235 W
Frequency response	PHONO	RIAA equalization curve $\pm 0.5$ dB
	CD, DAT, TAPE 1,2 VIDEO 1,2,3	10 Hz - 20 kHz $^{+0}_{-1}$ dB
Damping factor (8 ohms, at 1kHz)		50
Input sensitivity/impedance	PHONO MM	2.5 mV, 50 kilohms
	CD, DAT, TAPE 1,2 VIDEO 1,2,3	250 mV 50 kilohms
S/N	PHONO MM	83 dB 76 dB** (A, 2.5mV)
	CD, DAT TAPE 1,2 VIDEO 1,2,3	85 dB 78 dB** (A, 150mV)

Output sensitivity/impedance	DAT OUT, TAPE OUT 1,2 VIDEO 1	250 mV 10 kilohms
	HEADPHONES	Accepts headphones of high and low impedance
MUTING		-20dB
DBFB		+10 dB at 70Hz

\*\* 78IHF

### Digital signal processor section

Modulation (A/D conversion)	High Density Linear Converter	
Demonstration (D/A conversion)	High Density Linear Converter (Pulse D/A Converter)	
Sampling frequency	48 kHz	
Equalizer	Band	3-band, Bass/Treble/Mid
	Turnover frequency	Bass: 125 Hz - 1 kHz Treble: 1 kHz - 8 kHz
	Center frequency	Mid: 54 Hz - 8 kHz
	Level	$\pm 10$ dB, 1 dB step
	Slope (Q)	3-step selectable, Wide, Mid, Narrow
Surround	ROOM SIZE	16-step adjustable
	WALL	16-step adjustable
	SEAT POSITION F/R	16-step adjustable
	SEAT POSITION L/R	16-step adjustable
	EFFECT LEVEL	20-step adjustable
	REVERB TIME	16-step adjustable
	DELAY TIME**	15.0 ms-30.0 ms, 0.1 ms step
	REAR LEVEL	+10 — -50 dB, 1 dB step
	CENTER LEVEL***	+10 — -50 dB, 1 dB step
	INPUT BALANCE	Automatic

\*\* (only in the DOLBY SUR mode)

\*\*\* (only in the DOLBY SUR, THEATER and LIVE modes)



### FM tuner section

Frequency range	87.5 - 108.0 MHz	
Antenna terminals	75 ohms, unbalanced	
Sensitivity at 50 dB	18.3 dBf, 4.5 $\mu$ V (mono) 38.3 dBf, 45 $\mu$ V (stereo)	
Usable sensitivity	11.2 dBf, 2 $\mu$ V (IHF)	
S/N	Mono	80 dB
	Stereo	74 dB
Harmonic distortion at 1 kHz	Mono	0.3 %
	Stereo	0.5 %
IM distortion	Mono	0.3 %
	Stereo	0.5 %
Separation	45 dB at 1 kHz	
Frequency response	30 Hz - 15 kHz $\pm 0.5$ dB	
Selectivity	60 dB at 400 kHz	
Capture ratio	1.2 dB	
AM suppression ratio	54 dB	
Image response ratio	70 dB	
IF response ratio	70 dB	
Spurious response ratio	80 dB	
RF intermodulation at 800 kHz	60 dB	
Auto tuning threshold	Low	30 dBf
	High	50 dBf

### AM tuner section

Frequency range	530 - 1,710 kHz (with 10 kHz interval) 531 - 1,710 kHz (with 9 kHz interval)
Antenna	Loop antenna
Usable sensitivity	50 dB/m (at 1,000 kHz or 999 kHz)
S/N	54 dB (at 50 mV/m)
Harmonic distortion	0.5% (50 mV/m, 400 Hz)
Selectivity	35 dB (9 kHz), 40 dB (10 kHz)
Auto tuning threshold	55 dB/m

### Video section

Inputs	VIDEO 1,2,3: 1 Vp-p 75 ohms
Outputs	VIDEO 1, MONITOR: 1 Vp-p 75 ohms

### General

System	Tuner section	PLL quartz-locked digital synthesizer system
	Preamplifier section	Low-noise NF type equalizer
	Power amplifier section	Pure-complimentary SEPP
Power requirements	120 V AC, 60 Hz	
Power consumption	USA model: 260 W Canada model: 320 VA	
AC outlets	Two switched, total 120 W/1 A max.	
Dimensions (including projecting parts and controls)	Approx. 430 x 148 x 385 mm (w/h/d) (17 x 5 $\frac{13}{16}$ x 15 $\frac{3}{16}$ inches)	
Mass	Approx. 13.2 kg (29 lb 2 oz)	

Supplied accessories      FM wire antenna (1)  
    AM loop antenna (1)  
    Remote commander (1)  
    Sony Batteries SUM-3(NS) (2)

Design and specifications are subject to change without notice.

# Quick Reference

When operate the unit consulting this Quick Reference, make sure that the unit and the various audio/video equipment are properly connected.

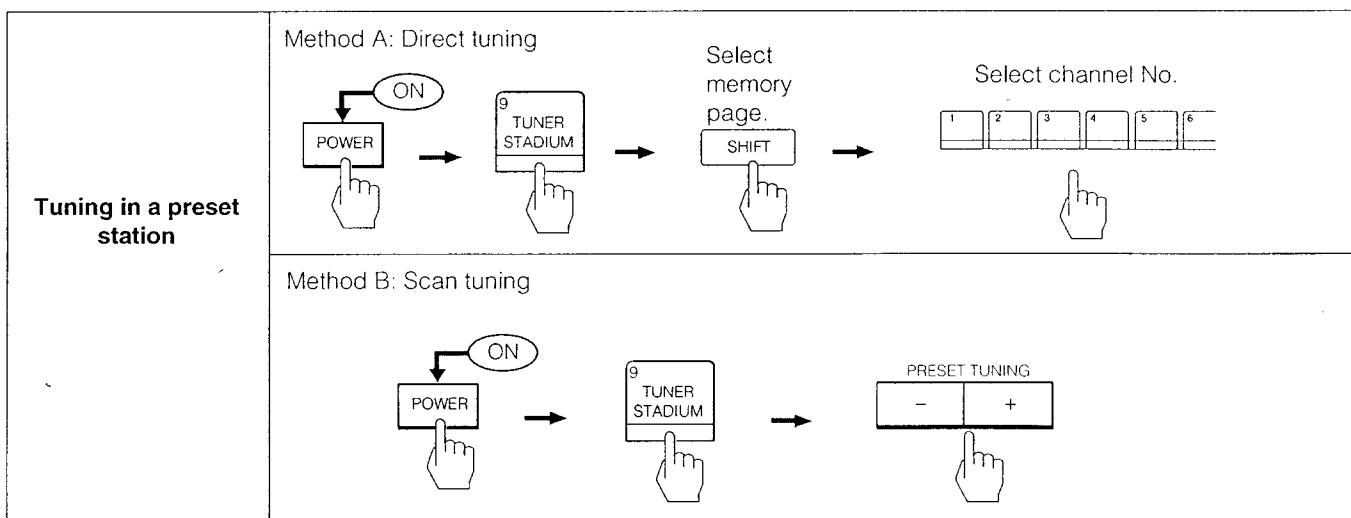
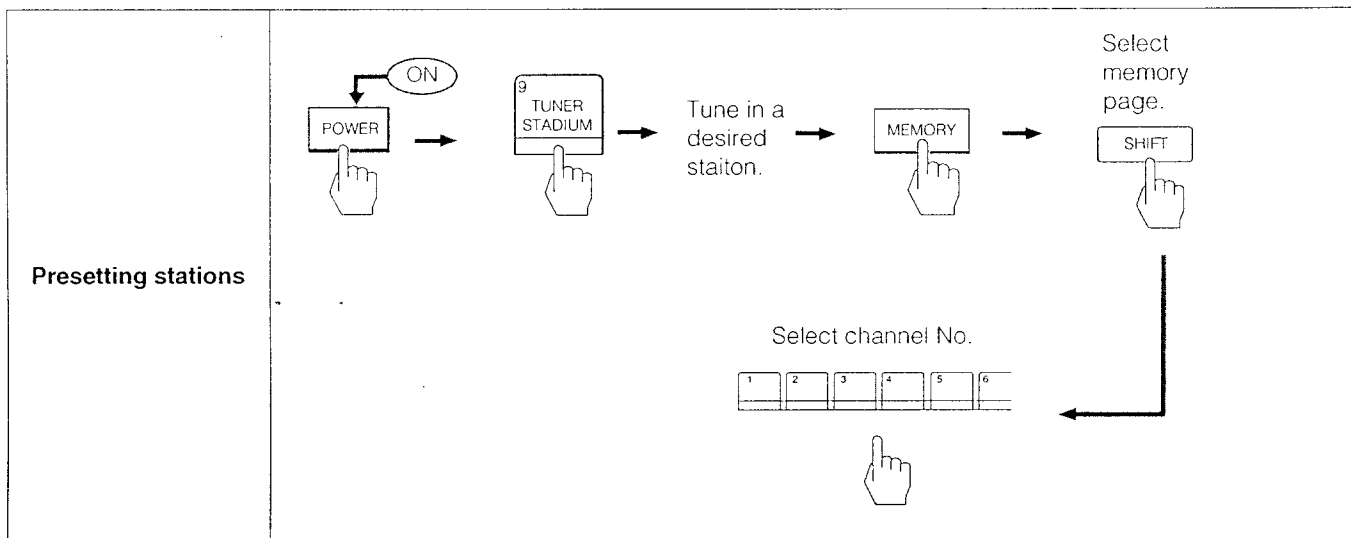
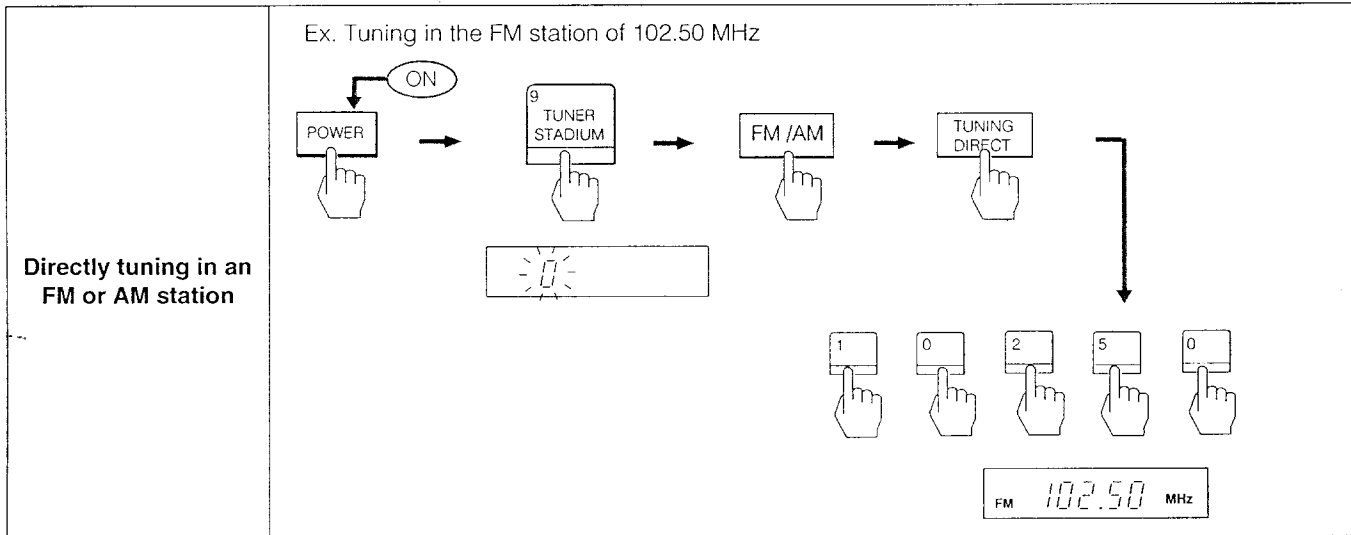

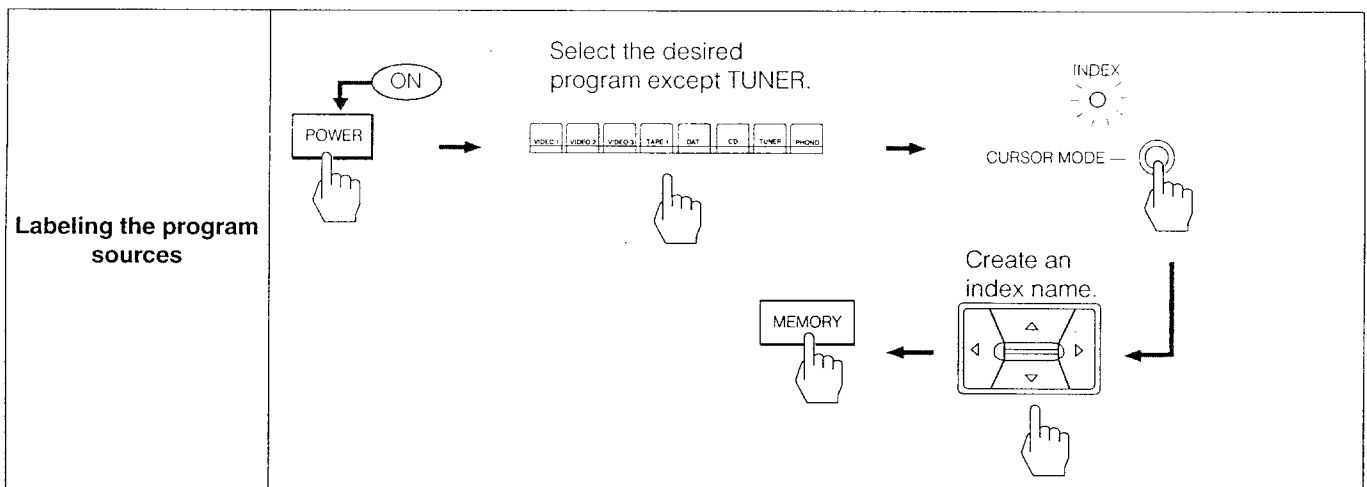
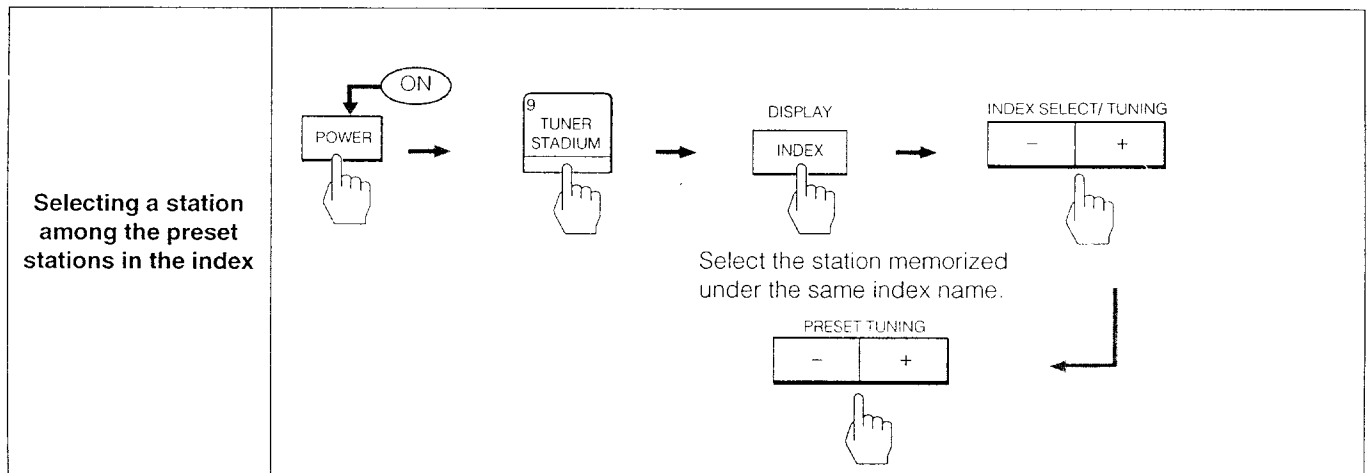
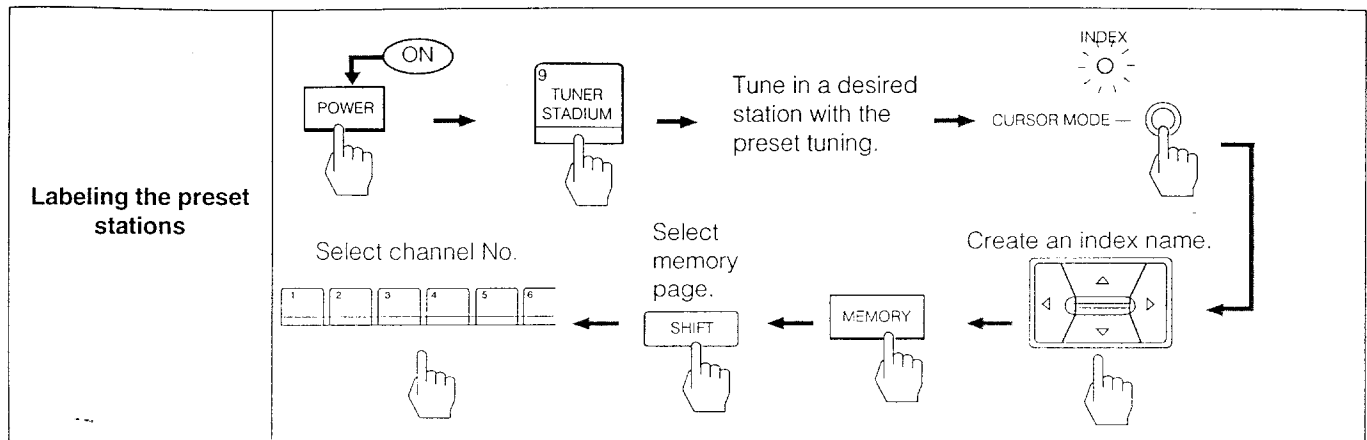

# Quick Reference

